

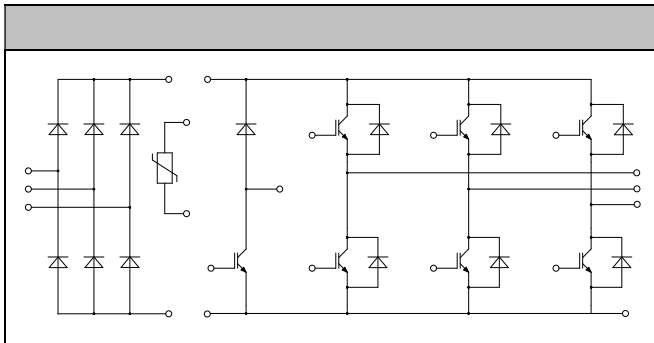

**120V**  
**75A**

**MicroDives**  
**AC and DC semiconductor amplifier**  
**UPS (Uninterruptible Power Supplies)**



**Low switching losses**  
**Low  $V_{CE(sat)}$  with positive temperature coefficient**  
**Including fast & soft recovery anti-parallel FWD**  
**Low inductance case**  
**High short circuit capability (10s)**  
**Maximum junction temperature 175°C**

<b>Collector-Emitter Voltage</b>	<b><math>V_{CES}</math></b>	<b><math>V_{CE}=0V, I_C=1mA, T_J=25</math></b>	<b>120</b>	<b>V</b>
<b>Continuous Collector Current</b>	<b><math>I_C</math></b>	<b><math>T_C=80</math> <math>v_{jmax} 175</math></b>	<b>75</b>	<b>A</b>
<b>Repetitive Peak Collector Current</b>	<b><math>I_{RM}</math></b>	<b><math>t_p=1ms</math></b>	<b>150</b>	<b>A</b>
<b>Gate-Emitter Voltage</b>	<b><math>V_{GES}</math></b>	<b><math>T_J=25</math></b>	<b>20</b>	<b>V</b>
<b>Total Power Dissipation</b>	<b><math>P_{tt}</math></b>	<b><math>T_C=25</math> <math>T_{jmax}=175</math></b>	<b>46</b>	<b>W</b>



<b>Gate-emitter Threshold Voltage</b>	$V_{GE(th)}$	$V_{GE}=V_{CE}, I_C=3mA, T_j=25$	<b>50</b>	<b>58</b>	<b>65</b>	<b>V</b>
<b>Collector-Emitter Cut-off Current</b>	$I_{CES}$	$V_{CE}=120V, V_{GE}=0V, T_j=25C$			<b>10</b>	<b>mA</b>
<b>Collector-Emitter Saturation Voltage</b>	$V_{CE(sat)}$	$I_C=75A, V_{GE}=15V, T_j=25$		<b>185</b>	<b>215</b>	<b>V</b>
		$I_C=75A, V_{GE}=15V, T_j=125$		<b>205</b>		
		$I_C=75A, V_{GE}=15V, T_j=150$		<b>210</b>		
<b>Gate Charge</b>	$Q_g$			<b>085</b>		<b>μC</b>
<b>Input Capacitance</b>	$C_{is}$	$V_{CE}=25V, V_{GE}=0V$		<b>420</b>		<b>rF</b>
<b>Reverse Transfer Capacitance</b>	$C_{res}$	$f=1MHz, T_j=25C$		<b>032</b>		<b>rF</b>
<b>Gate-Emitter leakage current</b>	$I_{GES}$	$V_{CE}=0V, V_{GE}=20V, T_j=25$			<b>40</b>	<b>mA</b>
<b>Turn-on Delay/line</b>	$t_{(on)}$	$I_C=75A$ $V_{CE}=60V$ $V_{GE}=\pm 15V$ $R_{\theta}=51$ $T_j=25$		<b>100</b>		<b>ns</b>
<b>Rise time</b>	$t_r$			<b>78</b>		<b>ns</b>
<b>Turn-off Delay/line</b>	$t_{(off)}$			<b>380</b>		<b>ns</b>
<b>Fall time</b>	$t_f$			<b>32</b>		<b>ns</b>
<b>Energy Dissipation During Turn-on/line</b>	$E_{on}$			<b>56</b>		<b>mJ</b>
<b>Energy Dissipation During Turn-off/line</b>	$E_{off}$			<b>36</b>		<b>mJ</b>
<b>Turn-on Delay/line</b>	$t_{(on)}$	$I_C=75A$ $V_{CE}=60V$ $V_{GE}=\pm 15V$ $R_{\theta}=51$ $T_j=125$		<b>110</b>		<b>ns</b>
<b>Rise time</b>	$t_r$			<b>85</b>		<b>ns</b>
<b>Turn-off Delay/line</b>	$t_{(off)}$			<b>40</b>		<b>ns</b>
<b>Fall time</b>	$t_f$			<b>36</b>		<b>ns</b>
<b>Energy Dissipation During Turn-on/line</b>	$E_{on}$			<b>88</b>		<b>mJ</b>
<b>Energy Dissipation During Turn-off/line</b>	$E_{off}$			<b>64</b>		<b>mJ</b>
<b>SCData</b>	$I_C$	$T_p=10s, V_{GE}=15V, T_j=150, V_{CE}=90V, V_{CEM}=120V$		<b>30</b>		<b>A</b>



<b>Repetitive Peak Reverse Voltage</b>	<b>V<sub>RRM</sub></b>	<b>T<sub>j</sub>=25</b>	<b>120</b>	<b>V</b>
<b>Continuous DC Forward Current</b>	<b>I<sub>F</sub></b>		<b>75</b>	<b>A</b>
<b>Repetitive Peak Forward Current</b>	<b>I<sub>FRM</sub></b>	<b>t<sub>F</sub>=1ms</b>	<b>150</b>	<b>A</b>
<b>R<sub>θjc</sub></b>	<b>R<sub>θ</sub></b>	<b>V<sub>F</sub>=0, t<sub>F</sub>=10ms, T<sub>j</sub>=125</b>	<b>810</b>	<b>As</b>
		<b>V<sub>F</sub>=0, t<sub>F</sub>=10ms, T<sub>j</sub>=150</b>	<b>600</b>	

<b>Forward Voltage</b>	<b>V<sub>F</sub></b>	<b>I<sub>F</sub>=75A, T<sub>j</sub>=25</b>		<b>220</b>	<b>260</b>	<b>V</b>
		<b>I<sub>F</sub>=75A, T<sub>j</sub>=125</b>		<b>225</b>		
		<b>I<sub>F</sub>=75A, T<sub>j</sub>=150</b>		<b>225</b>		
<b>Recovered Charge</b>	<b>Q<sub>r</sub></b>	<b>I<sub>F</sub>=75A</b>		<b>42</b>		<b>μC</b>
<b>Peak Reverse Recovery Current</b>	<b>I<sub>r</sub></b>	<b>V<sub>R</sub>=60V</b> <b>-d<sub>F</sub>/d<sub>t</sub>=90A/μs</b>		<b>75</b>		<b>A</b>
<b>Reverse Recovery Energy</b>	<b>E<sub>rec</sub></b>	<b>T<sub>j</sub>=25</b>		<b>206</b>		<b>nJ</b>
<b>Recovered Charge</b>	<b>Q<sub>r</sub></b>	<b>I<sub>F</sub>=75A</b>		<b>96</b>		<b>μC</b>
<b>Peak Reverse Recovery Current</b>	<b>I<sub>r</sub></b>	<b>V<sub>R</sub>=60V</b> <b>-d<sub>F</sub>/d<sub>t</sub>=90A/μs</b>		<b>92</b>		<b>A</b>
<b>Reverse Recovery Energy</b>	<b>E<sub>rec</sub></b>	<b>T<sub>j</sub>=125</b>		<b>431</b>		<b>nJ</b>



<b>Collector-Emitter Voltage</b>	$V_{CES}$	$V_{GE}=0V, I_C=1mA, T_j=25$	<b>120</b>	<b>V</b>
<b>Continuous Collector Current</b>	$I_C$	$T_C=100 \quad V_{jmax}=175$	<b>50</b>	<b>A</b>
<b>Repetitive Peak Collector Current</b>	$I_{CRM}$	$t_p=1ms$	<b>100</b>	<b>A</b>
<b>Gate-Emitter Voltage</b>	$V_{GES}$	$T_j=25$	<b>20</b>	<b>V</b>
<b>Total Power Dissipation</b>	$P_{tot}$	$T_C=25$ $T_{jmax}=175$	<b>42</b>	<b>W</b>

<b>Gate-emitter Threshold Voltage</b>	$V_{GE(th)}$	$V_{GE}=V_{CE}, I_C=1.7mA, T_j=25$	<b>50</b>	<b>57</b>	<b>65</b>	<b>V</b>
<b>Collector-Emitter Cut-off Current</b>	$I_{CES}$	$V_{CE}=120V, V_{GE}=0V, T_j=25C$			<b>10</b>	<b>nA</b>
<b>Collector-Emitter Saturation Voltage</b>	$V_{CE(sat)}$	$I_C=50A, V_{GE}=15V, T_j=25$		<b>190</b>	<b>225</b>	<b>V</b>
		$I_C=50A, V_{GE}=15V, T_j=125$		<b>225</b>		
		$I_C=50A, V_{GE}=15V, T_j=150$		<b>235</b>		
<b>Gate Charge</b>	$Q_g$			<b>035</b>		<b><math>\mu C</math></b>
<b>Input Capacitance</b>	$C_{is}$	$V_{CE}=25V, V_{GE}=0V$		<b>260</b>		<b>pF</b>
<b>Reverse Transfer Capacitance</b>	$C_{res}$	$f=1MHz, T_j=25C$		<b>010</b>		<b>pF</b>
<b>Gate-Emitter leakage current</b>	$I_{GES}$	$V_{CE}=0V, V_{GE}=20V, T_j=25$			<b>400</b>	<b>nA</b>
<b>Turn-on Delay/line</b>	$t_{on}$	$I_C=50A$ $V_{CE}=60V$ $V_{GE}=\pm 15V$ $R_g=15$ $T_j=25$		<b>168</b>		<b>ns</b>
<b>Rise Time</b>	$t_r$			<b>31</b>		<b>ns</b>
<b>Turn-off Delay/line</b>	$t_{off}$			<b>30</b>		<b>ns</b>
<b>Fall Time</b>	$t_f$			<b>78</b>		<b>ns</b>
<b>Energy Dissipation During Turn-on</b>	$E_{on}$			<b>542</b>		<b>nJ</b>
<b>Energy Dissipation During Turn-off</b>	$E_{off}$			<b>415</b>		<b>nJ</b>



<b>TurnonDelay/line</b>	$t_{on}$	$I_C=50A$ $V_{CE}=60V$ $V_{GE}=\pm 15V$ $R_G=15$ $T_J=125$	<b>175</b>	<b>ns</b>
<b>Rise/line</b>	$t_r$		<b>42</b>	<b>ns</b>
<b>TurnoffDelay/line</b>	$t_{off}$		<b>46</b>	<b>ns</b>
<b>Fall/line</b>	$t_f$		<b>148</b>	<b>ns</b>
<b>Energy Dissipation During Turnon/line</b>	$E_{on}$		<b>726</b>	<b>nJ</b>
<b>Energy Dissipation During Turnoff/line</b>	$E_{off}$		<b>580</b>	<b>nJ</b>
<b>SCData</b>	$I_C$	$T_P=10\mu s, V_{CE}=15V, T_J=150$ , $V_{CE}=90V, V_{CEM}=120V$	<b>280</b>	<b>A</b>

<b>RepetitivePeakReverseVoltage</b>	$V_{RRM}$	$T_J=25$	<b>120</b>	<b>V</b>
<b>ContinuousDCForwardCurrent</b>	$I_F$		<b>35</b>	<b>A</b>
<b>RepetitivePeakForwardCurrent</b>	$I_{FRM}$	$t_p=1ms$	<b>70</b>	<b>A</b>
<b>Rvalue</b>	$R_\theta$	$V_{CE}=0, t_p=10ms, T_J=125$	<b>20</b>	<b>As</b>
		$V_{CE}=0, t_p=10ms, T_J=150$	<b>20</b>	

<b>ForwardVoltage</b>	$V_F$	$I_F=35A, T_J=25$ $I_F=35A, T_J=125$ $I_F=35A, T_J=150$	<b>195</b> <b>195</b> <b>190</b>	<b>V</b>
<b>RecoveredCharge</b>	$Q_r$	$I_F=35A$	<b>415</b>	<b><math>\mu C</math></b>
<b>PeakReverseRecoveryCurrent</b>	$I_{rr}$	$V_{CE}=60V$ $-d_f/d=160A/\mu s$	<b>42</b>	<b>A</b>
<b>ReverseRecoveryEnergy</b>	$E_{rec}$	$T_J=25$	<b>130</b>	<b>nJ</b>
<b>RecoveredCharge</b>	$Q_r$	$I_F=35A$	<b>800</b>	<b><math>\mu C</math></b>
<b>PeakReverseRecoveryCurrent</b>	$I_{rr}$	$V_{CE}=60V$ $-d_f/d=160A/\mu s$	<b>46</b>	<b>A</b>
<b>ReverseRecoveryEnergy</b>	$E_{rec}$	$T_J=125$	<b>238</b>	<b>nJ</b>



<b>Repetitive Peak Reverse Voltage</b>	<b><math>V_{RRM}</math></b>	<b><math>T_J=25</math></b>	<b>160</b>	<b>V</b>
<b>Average Output Current 50kHz, sine wave</b>	<b><math>I_{(A)}</math></b>	<b><math>T_C=100</math></b>	<b>80</b>	<b>A</b>
<b>Minimum RMS Current at Rectifier Output</b>	<b><math>I_{RSM}</math></b>	<b><math>T_C=100</math></b>	<b>120</b>	<b>A</b>
<b>Surge Forward Current</b>	<b><math>I_{SM}</math></b>	<b><math>V_F=0, t_F=10ms, T_J=25</math></b>	<b>1100</b>	<b>A</b>
<b>ft value</b>	<b>ft</b>	<b><math>V_F=0, t_F=10ms, T_J=25</math></b>	<b>600</b>	<b>ns</b>

<b>Diode Forward Voltage</b>	<b><math>V_F</math></b>	<b><math>I_F=50A, T_J=125</math></b>	<b>0.98</b>	<b>V</b>
<b>Reverse Current</b>	<b><math>I_R</math></b>	<b><math>T_J=125, V_R=160V</math></b>	<b>20</b>	<b>mA</b>

<b>Rated Resistance</b>	<b><math>R_Z</math></b>		<b>50</b>	<b>k</b>
<b>Deviation of R10D</b>	<b>RR</b>	<b><math>T_C=100, R_{10D}=483</math></b>	<b>-5</b>	<b>5</b> %
<b>Power Dissipation</b>	<b><math>P_Z</math></b>			<b>200</b> mW
<b>B value</b>	<b><math>B_{250}</math></b>	<b><math>R_Z=R_Z \exp(B_{250}(1/T_2 - 1/298.15))</math></b>	<b>335</b>	<b>K</b>



<b>Isolation Voltage</b>	<b>V<sub>sd</sub></b>	<b>t=1min@50Hz</b>	<b>250</b>			<b>V</b>
<b>Minimum Junction Temperature</b>	<b>T<sub>jmin</sub></b>				<b>175</b>	
<b>Operating Junction Temperature</b>	<b>T<sub>jq</sub></b>		<b>-40</b>		<b>150</b>	
<b>Storage Temperature</b>	<b>T<sub>stg</sub></b>		<b>-40</b>		<b>125</b>	
<b>Staying Inductance</b>	<b>I<sub>SC</sub></b>			<b>6</b>		9
<b>Module lead resistance, terminals dip</b>	<b>R<sub>GE</sub></b>	<b>T<sub>c</sub>=25 , per switch</b>		<b>40</b>		
	<b>R<sub>MC</sub></b>			<b>30</b>		
<b>Thermal Resistance Junction to Case</b>	<b>R<sub>JC</sub></b>	<b>per GBT in meter</b>			<b>039</b>	<b>KW</b>
		<b>per Diode in meter</b>			<b>069</b>	
		<b>per GBT base copper</b>			<b>050</b>	
		<b>per Diode copper</b>			<b>126</b>	
		<b>per Diode solder</b>			<b>085</b>	
<b>Thermal Resistance Case to Sink</b>	<b>R<sub>CS</sub></b>	<b>per GBT in meter</b>		<b>0121</b>		<b>KW</b>
		<b>per Diode in meter</b>		<b>0221</b>		
		<b>per GBT base copper</b>		<b>0180</b>		
		<b>per Diode copper</b>		<b>0452</b>		
		<b>per Diode solder</b>		<b>0227</b>		
		<b>per Module</b>		<b>009</b>		
<b>Mating Force Per Clamp</b>	<b>F</b>		<b>30</b>		<b>60</b>	<b>N</b>
<b>Weight of Module</b>	<b>G</b>			<b>300</b>		<b>g</b>





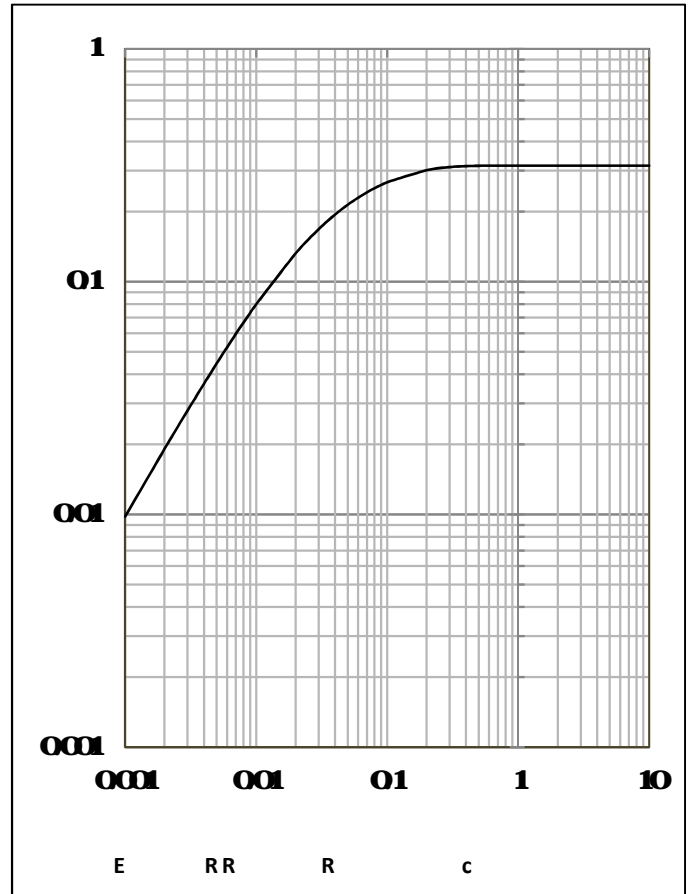
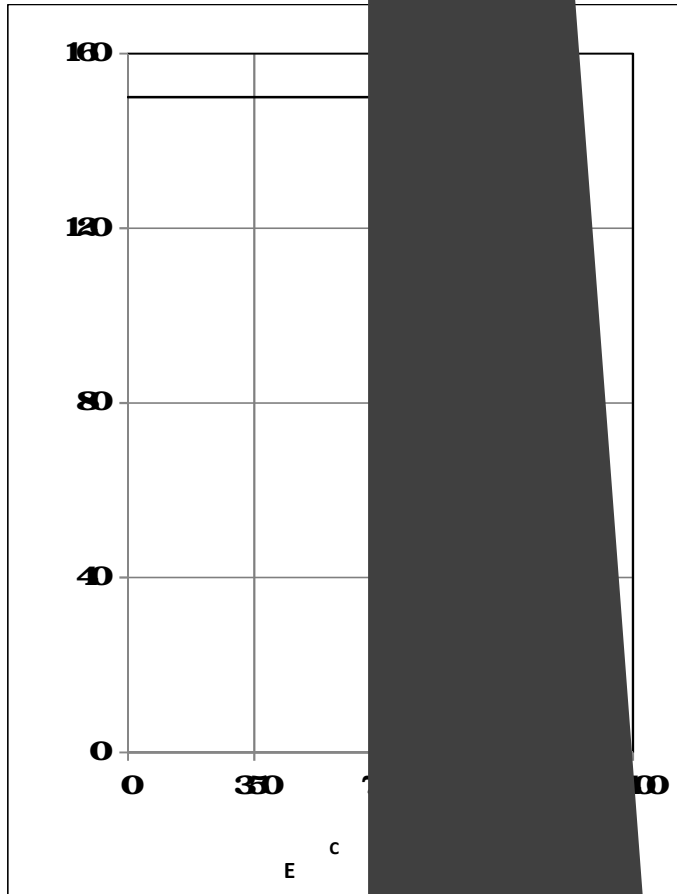

---



---



---



---



---



---



---

