

DIP4, DC Input, Photo Transistor Coupler

Description

Features

Applications

-
-
-
-

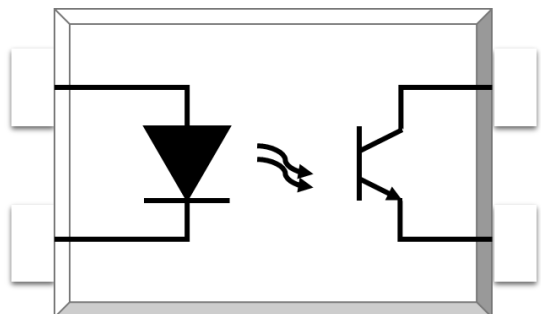
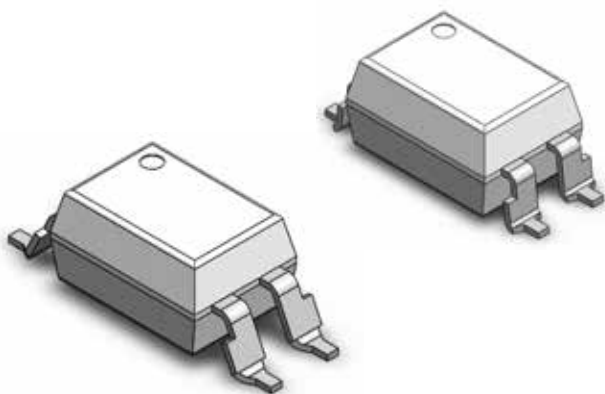
SCHEMATIC

PIN DEFINITION
<ol style="list-style-type: none">1. Anode2. Cathode3. Emitter4. Collector
PACKAGE OUTLINE

DIP4, DC Input, Photo Transistor Coupler

ELECTRICAL OPTICAL CHARACTERISTICS at Ta=25°C

--	--	--	--	--	--	--	--	--	--

CHARACTERISTIC CURVES

Fig.1 Forward Current vs. Ambient Temperature

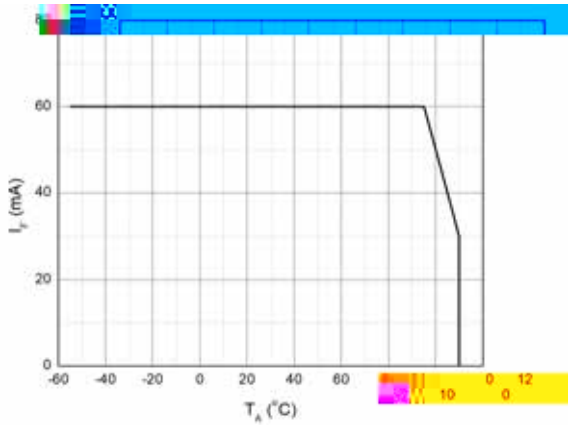

Fig.2 Collector Power Dissipation vs. Ambient Temperature

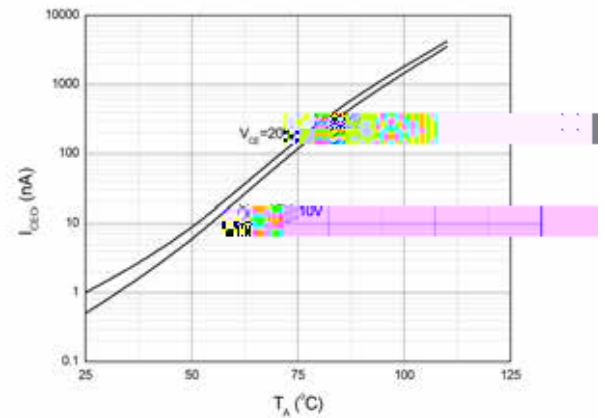

Fig.3 Forward Current vs. Forward Voltage

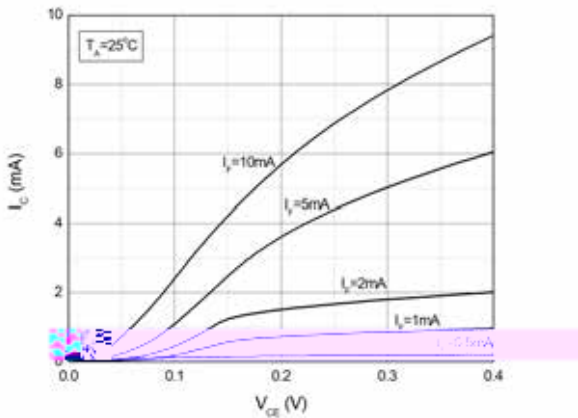

Fig.4 Collector Dark Current vs. Ambient Temperature

Fig.6 Collector Current vs. Collector-emitter Voltage

TD817 Series

TEST CIRCUITS

Fig.12 Test Circuits of Response Time

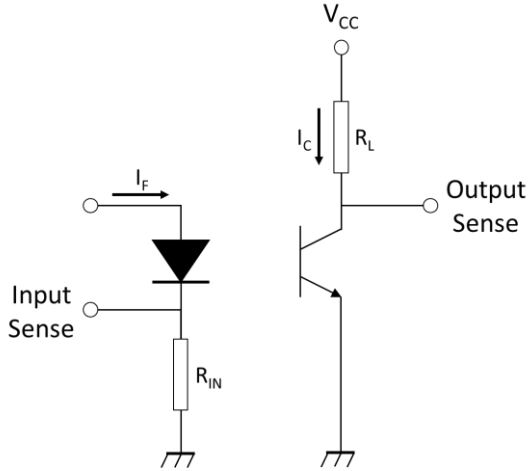

Fig.13 Curves of Response Time

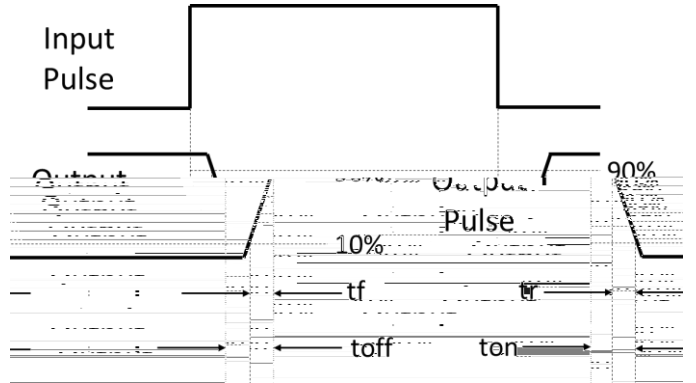
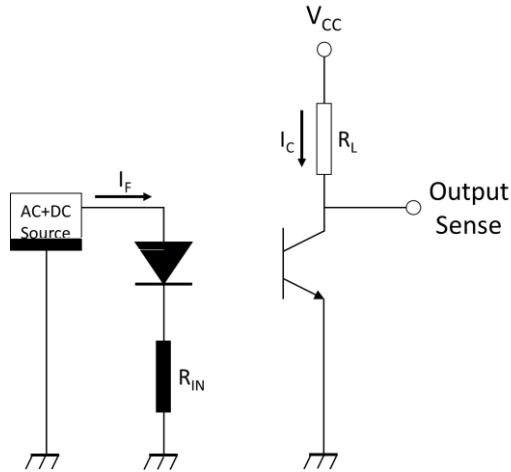

Fig.14 Test Circuits of Frequency Response



DIP4, DC Input, Photo Transistor Coupler

PACKAGE DIMENSIONS Dimensions in mm unless otherwise stated)

Standard DIP – Through Hole (DIP Type)

Gullwing (400mil) Lead Forming – Through Hole (M Type)

DIP4, DC Input, Photo Transistor Coupler

PACKAGE DIMENSIONS Dimensions in mm unless otherwise stated)

Surface Mount Lead Forming (S Type)

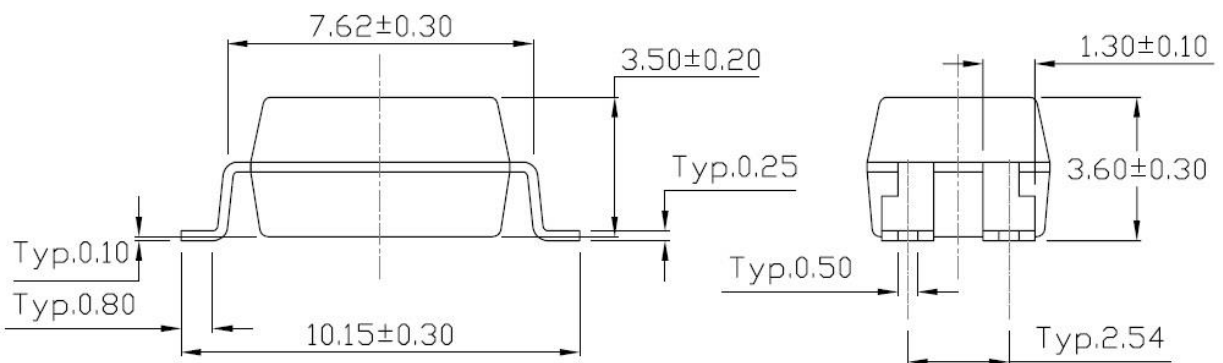
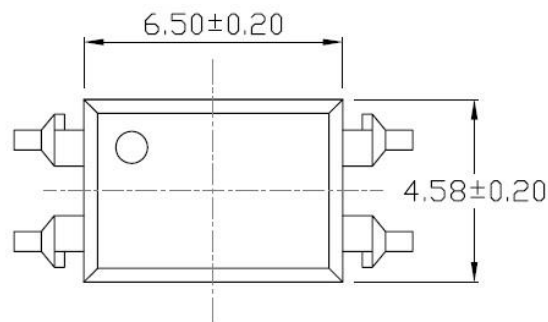

DIP4, DC Input, Photo Transistor Coupler

PACKAGE DIMENSIONS Dimensions in mm unless otherwise stated)

Surface Mount (Gullwing) Lead Forming (SLM Type)

RECOMMENDED SOLDER MASK Dimensions in mm unless otherwise stated)

Surface Mount Lead Forming & Surface Mount (Low Profile) Lead Forming

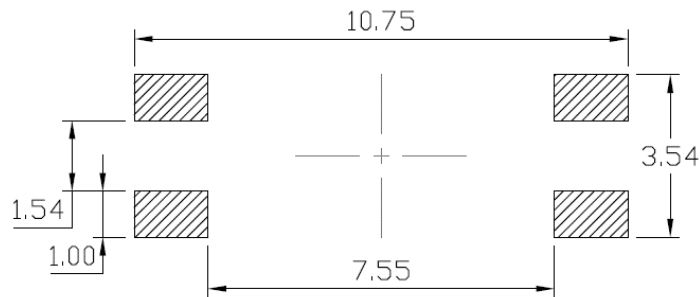

Surface Mount (Gullwing) Lead Forming

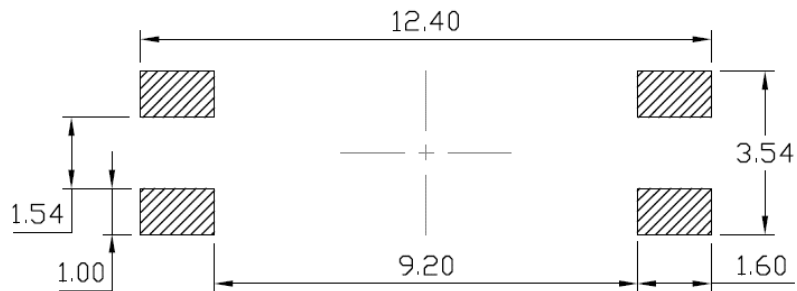

DIP4, DC Input, Photo Transistor Coupler

TUBE SPECIFICATIONS Dimensions in mm unless otherwise stated)

Standard DIP

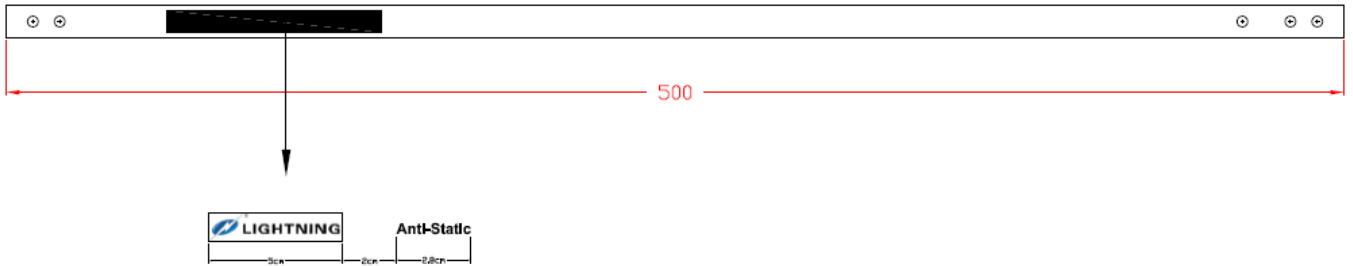
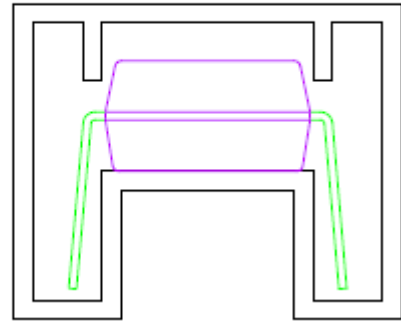
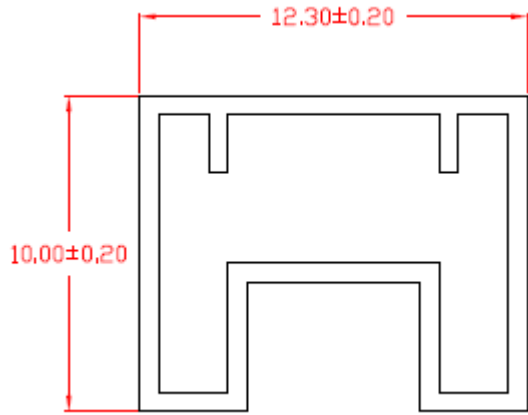

Option M

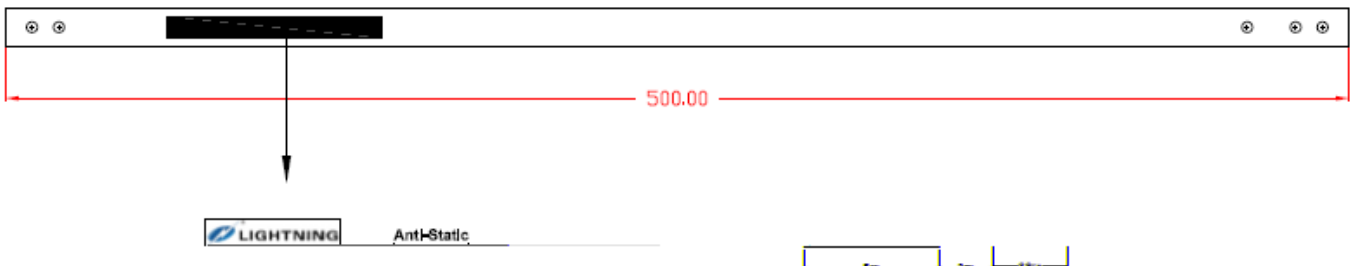
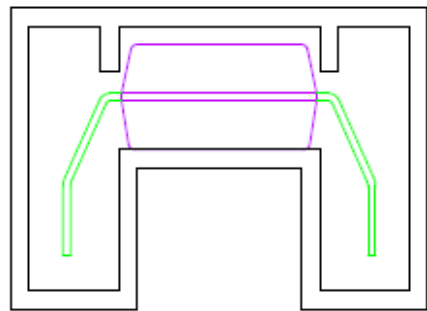
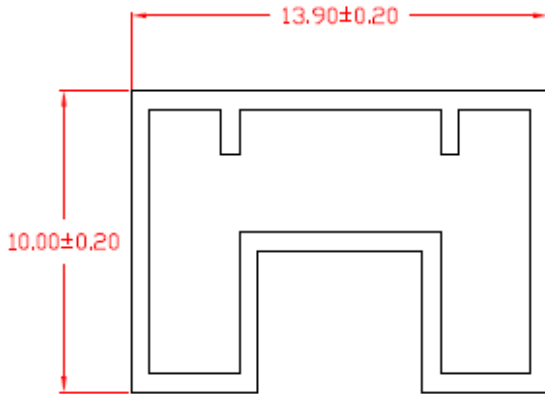

DIP4, DC Input, Photo Transistor Coupler

BOX SPECIFICATIONS Tube Type)

Inner Box

Label



L x W x H = 52.5cm x 10.7cm x 4.7cm

Outer Box

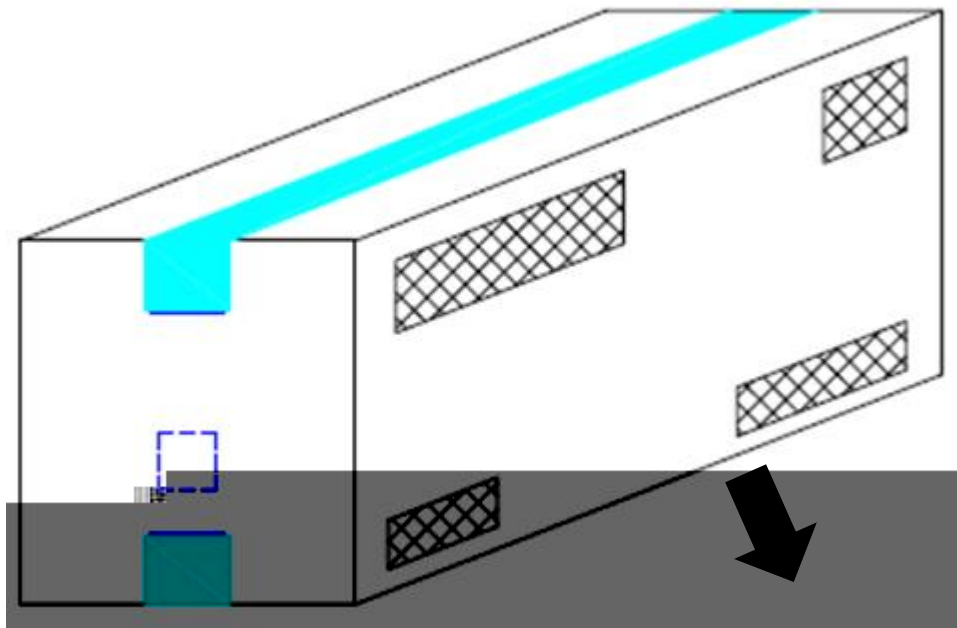

L x W x H = 53.5cm x 23.5cm x 25.5cm

CARRIER TAPE SPECIFICATIONS Dimensions in mm unless otherwise stated)

Option S(T1) & SL(T1)

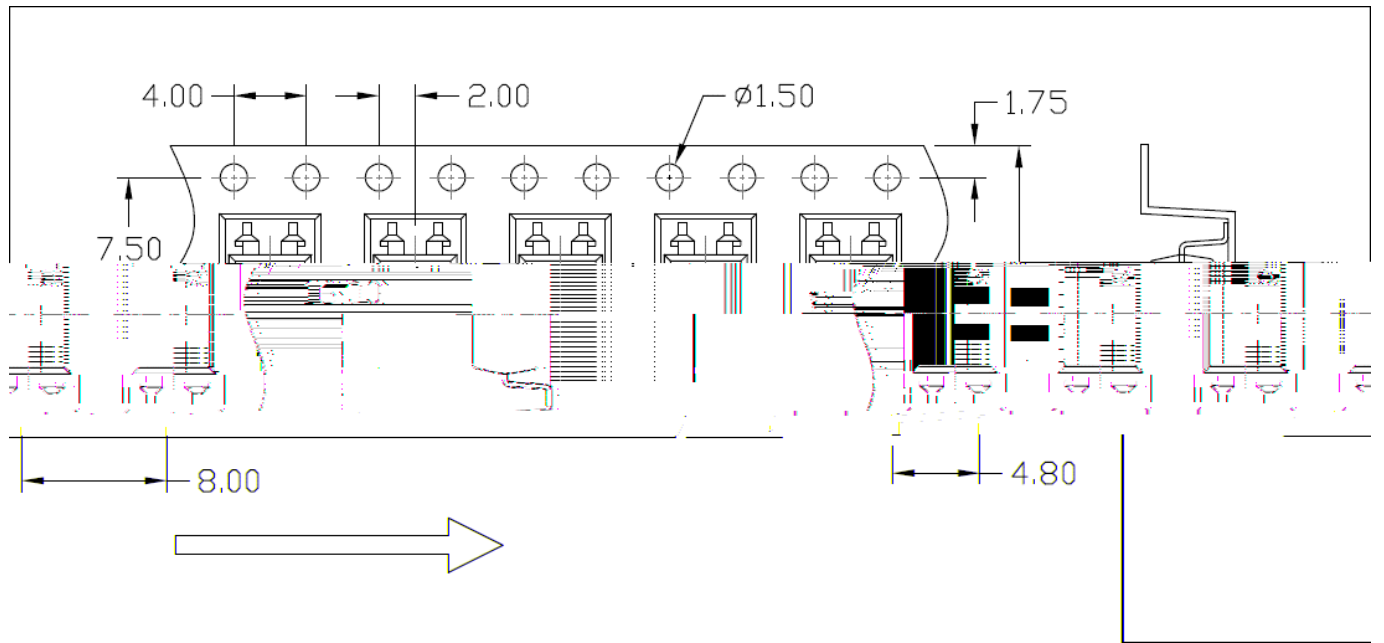

Option S(T2) & SL(T2)

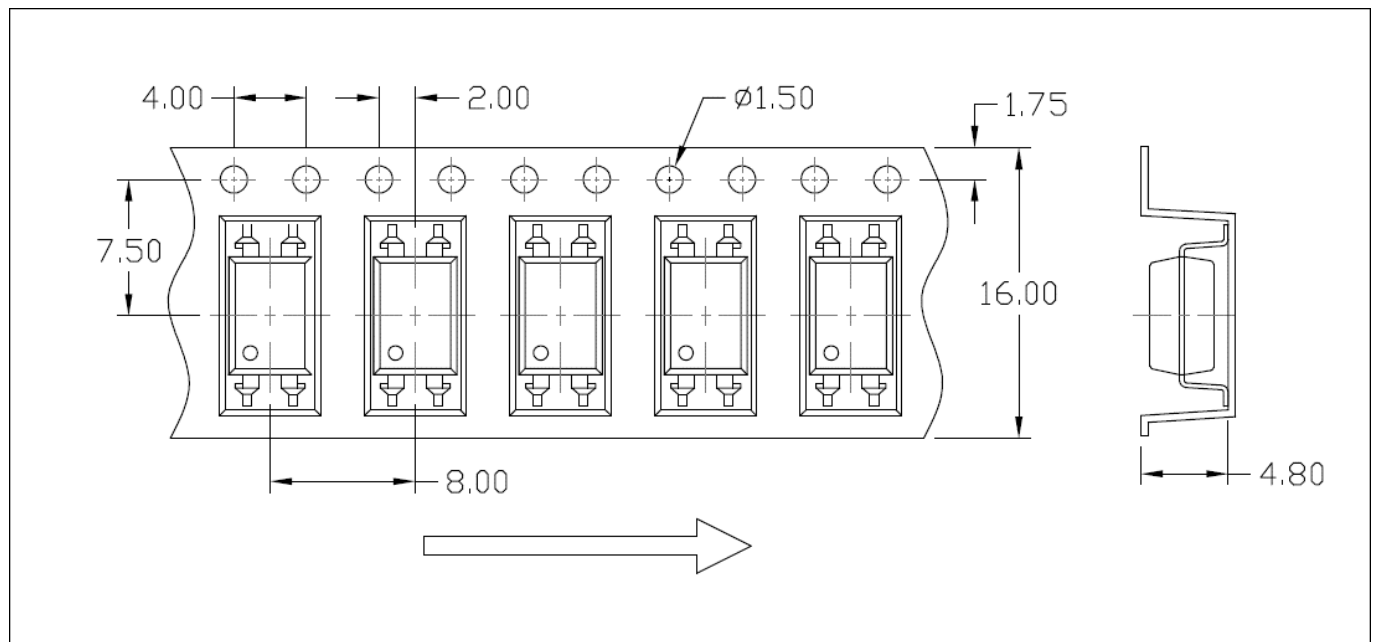

CARRIER TAPE SPECIFICATIONS Dimensions in mm unless otherwise stated)

Option S(T3) & SL(T3)

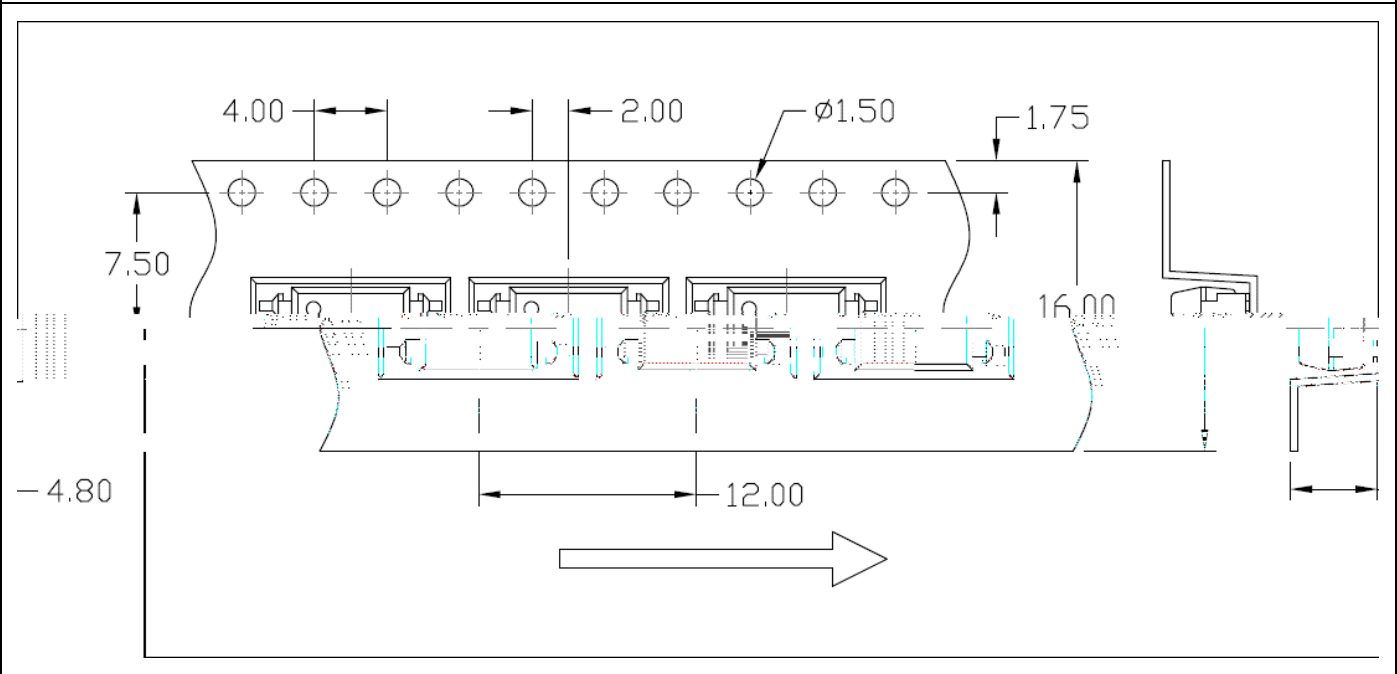

Option S(T4) & SL(T4)

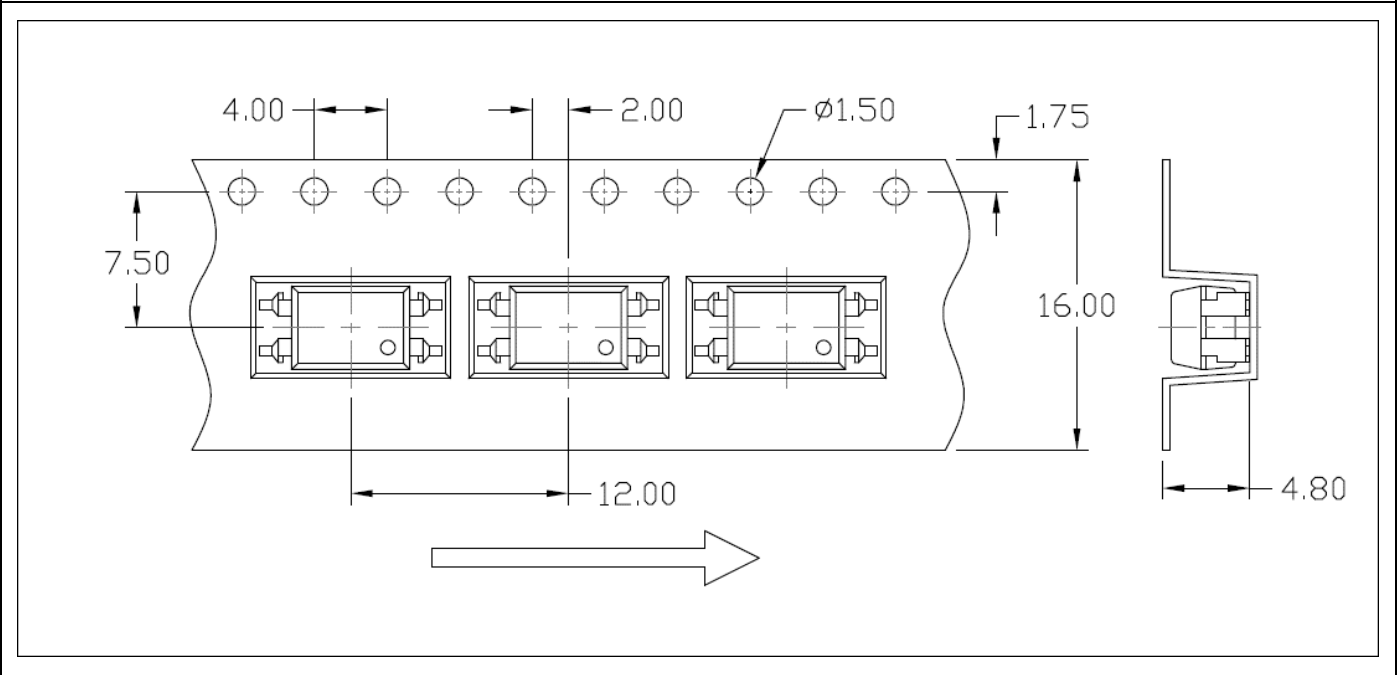

DIP4, DC Input, Photo Transistor Coupler

CARRIER TAPE SPECIFICATIONS Dimensions in mm unless otherwise stated)

Option SLM(T1)

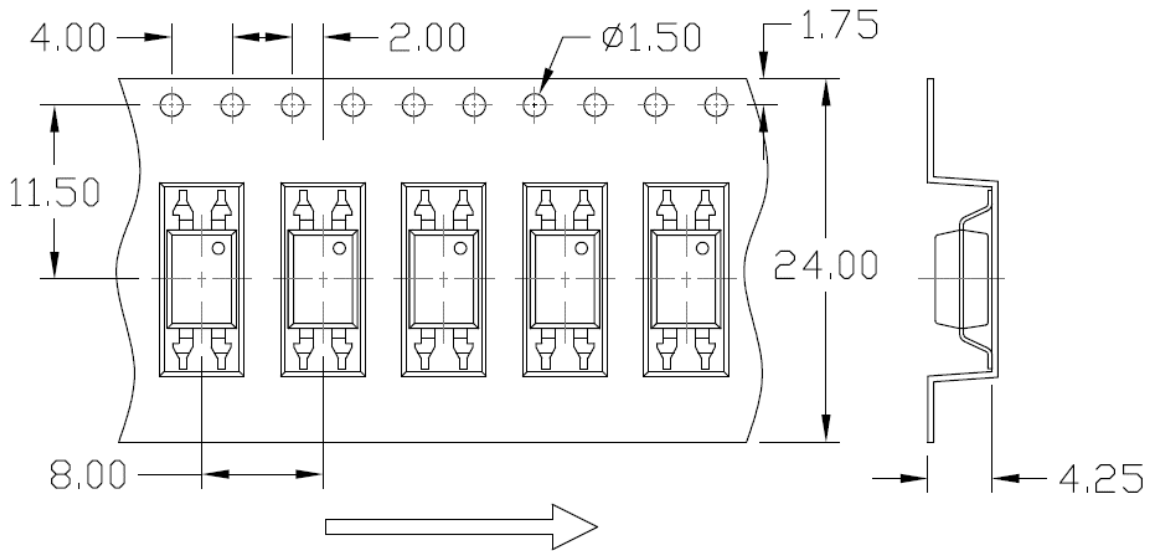

Option SLM(T2)

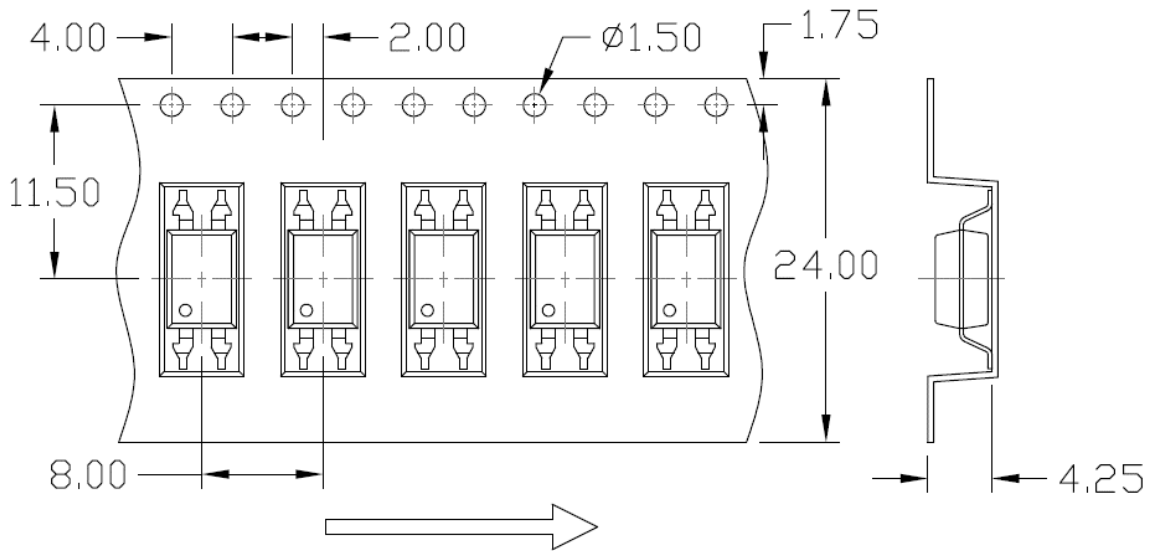

DIP4, DC Input, Photo Transistor Coupler

REEL SPECIFICATIONS Dimensions in mm unless otherwise stated)

Option S & Option SL

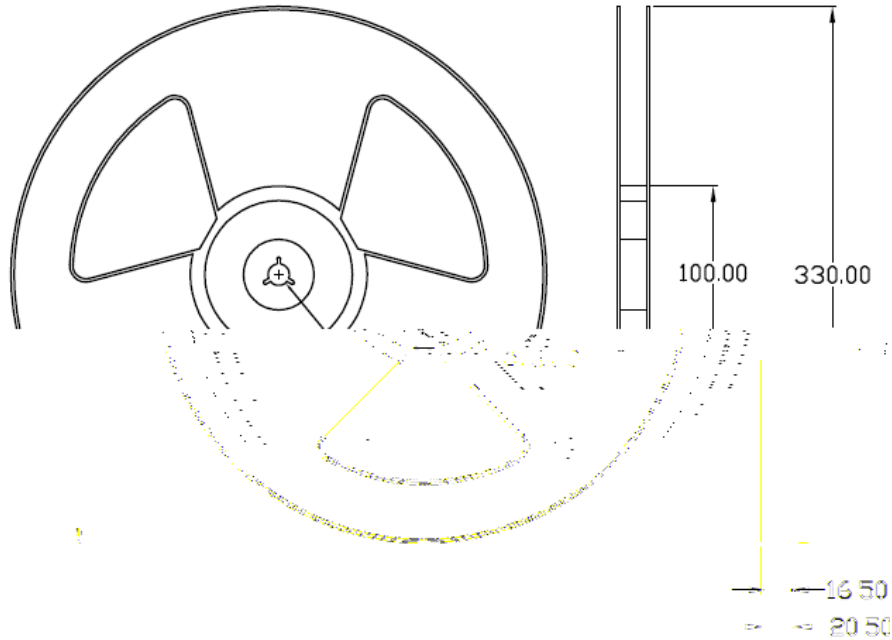

Option SLM

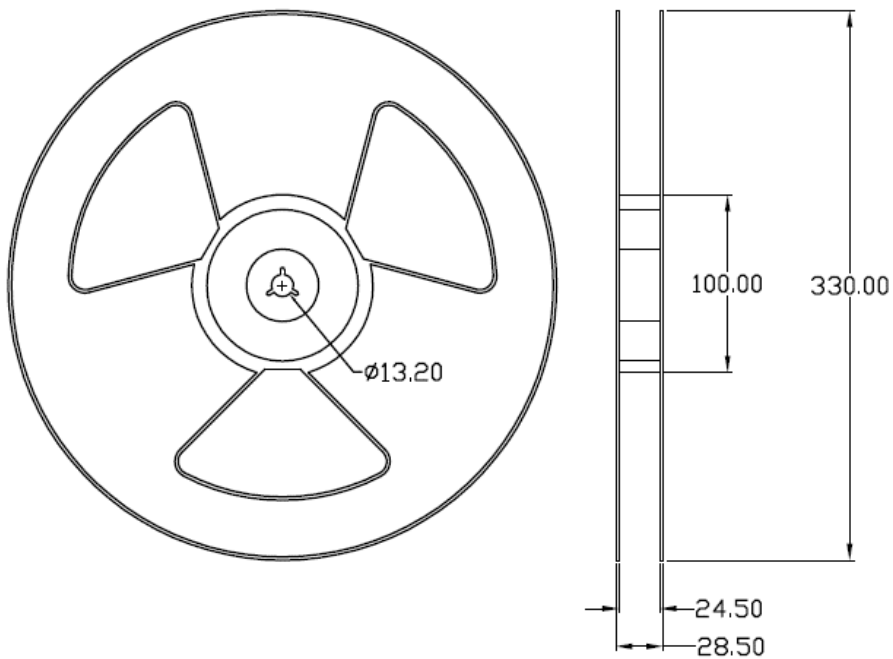

BOX SPECIFICATIONS (Reel Type)

Inner Box

L x W x H = 36cm x 36cm x 6.9cm

Outer Box

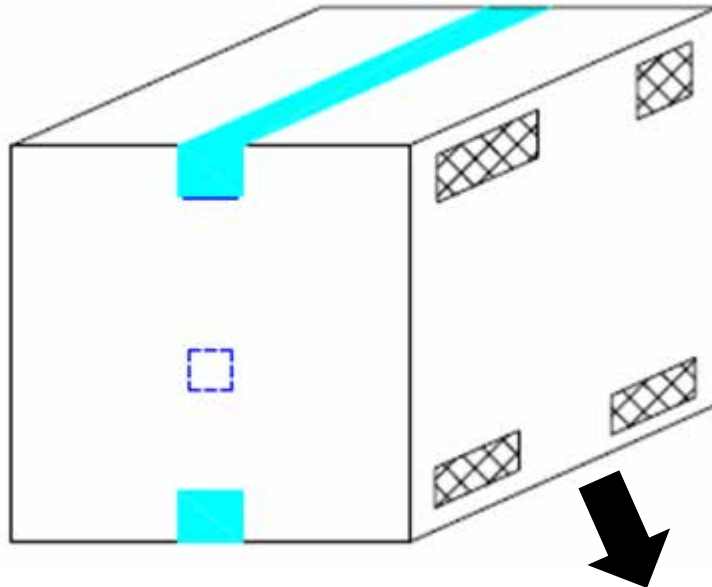

L x W x H = 45cm x 38cm x 38cm

DIP4, DC Input, Photo Transistor Coupler

ORDERING AND MARKING INFORMATION

MARKING INFORMATION

TD : Company Abbr.
F : Leadframe Option
817 : Part Number
X : CTR Rank
V

DIP4, DC Input, Photo Transistor Coupler

TEMPERATURE PROFILE OF SOLDERING

WAVE SOLDERING (JESD22-A111 COMPLIANT)

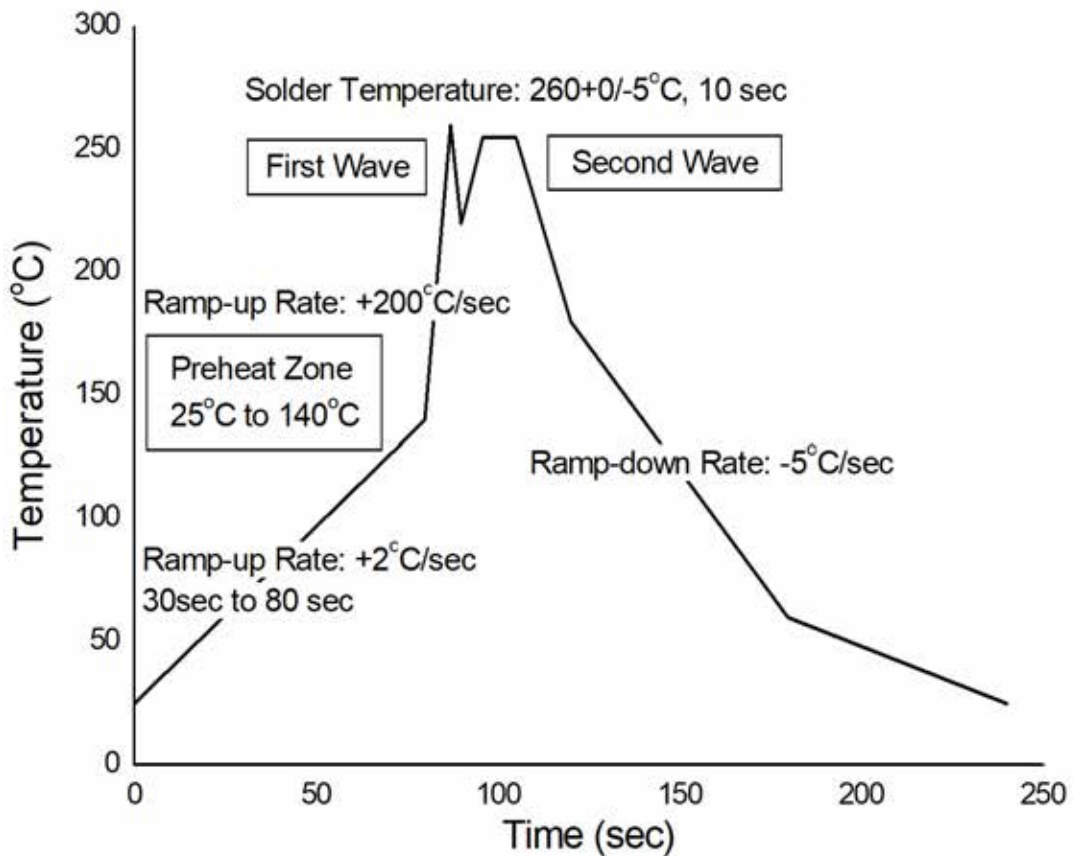

HAND SOLDERING BY SOLDERING IRON

- One time soldering is recommended for all soldering method.
- Do not solder more than three times for IR reflow soldering.

TD817 Series
DIP4, DC Input, Photo Transistor Coupler