

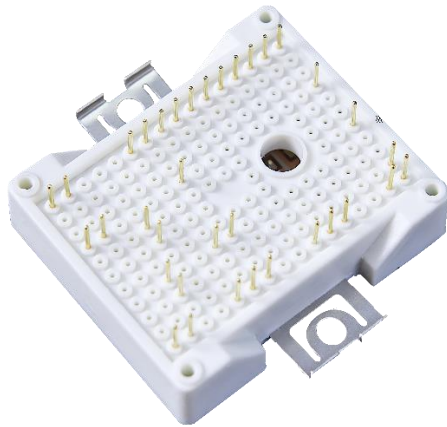

MG15P12P3



1200V
15A

Motor Drivers
AC and DC Servo Drive Amplifier
UPS (Uninterruptible Power Supplies)

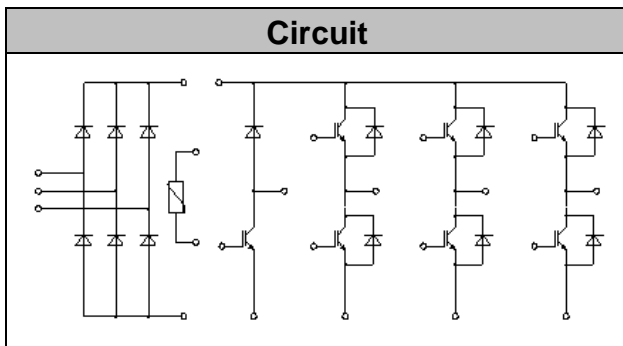

Low switching losses
Low $V_{CE(sat)}$ with positive temperature coefficient
Including fast & soft recovery anti-parallel FWD
Low inductance case
High short circuit capability(10us)
Isolated heatsink using DBC technology
Maximum junction temperature 175

Collector-Emitter Voltage	V_{CES}	$V_{GE}=0V, I_C = 1mA, T_{vj}=25$	1200	V
Continuous Collector Current	I_C	$T_C=100$ $v_{jmax} 175$	15	A
Repetitive Peak Collector Current	I_{CRM}	$t_p=1ms$	30	A
Gate-Emitter Voltage	V_{GES}	$T_{vj}=25$	20	V
Total Power Dissipation	P_{tot}	$T_C=25$ $T_{vjmax}=175$	155	W

Gate-Emitter Threshold Voltage	$V_{GE(th)}$	$V_{GE}=V_{CE}, I_C=0.5mA, T_{vj}=25$	5.2	5.8	6.4	V	
Collector-Emitter Cut-off Current	I_{CES}	$V_{CE}=1200V, V_{GE}=0V, T_{vj}=25$			1.0	mA	
Collector-Emitter Saturation Voltage	$V_{CE(sat)}$	$I_C=15A, V_{GE}=15V, T_{vj}=25$		1.80	2.20	V	
		$I_C=15A, V_{GE}=15V, T_{vj}=125$		2.10			
		$I_C=15A, V_{GE}=15V, T_{vj}=150$		2.20			
Gate Charge	Q_G			0.15		uC	
Input Capacitance	C_{ies}	$V_{CE}=25V, V_{GE}=0V, f=1MHz, T_{vj}=25$		1.1		nF	
Reverse Transfer Capacitance	C_{res}			0.04		nF	
Gate-Emitter leakage current	I_{GES}	$V_{CE}=0V, V_{GE}=20V, T_{vj}=25$			400	nA	
Turn-on Delay Time	$t_{d(on)}$	$I_C=15A, V_{CE}=600V, V_{GE}=\pm 15V, R_G=39, T_{vj}=25$		90		ns	
Rise Time	t_r			64		ns	
Turn-off Delay Time	$t_{d(off)}$			180		ns	
Fall Time	t_f			135		ns	
Energy Dissipation During Turn-on Time	E_{on}			1.42		mJ	
Energy Dissipation During Turn-off Time	E_{off}			0.78		mJ	
Turn-on Delay Time	$t_{d(on)}$		$I_C=15A, V_{CE}=600V, V_{GE}=\pm 15V, R_G=39, T_{vj}=125$		95		ns
Rise Time	t_r				70		ns
Turn-off Delay Time	$t_{d(off)}$				260		ns
Fall Time	t_f				180		ns
Energy Dissipation During Turn-on Time	E_{on}			1.85		mJ	
Energy Dissipation During Turn-off Time	E_{off}			1.13		mJ	
SC Data	I_{SC}	$t_p=10\mu s, V_{GE}=15V, T_{vj}=150, V_{CC}=900V, V_{CEM}=1200V$			90		A

Repetitive Peak Reverse Voltage	V_{RRM}	$T_{vj}=25$	1200	V
Continuous DC Forward Current	I_F		15	A
Repetitive Peak Forward Current	I_{FRM}	$t_p=1ms$	30	A
I ² t-value	I ² t	$V_R=0V, t_p=10ms, T_{vj}=125$	16.0	A ² s
		$V_R=0V, t_p=10ms, T_{vj}=150$	14.0	

Forward Voltage	V_F	$I_F=15A, T_{vj}=25$		2.00	2.65	V
		$I_F=15A, T_{vj}=125$		2.10		
		$I_F=15A, T_{vj}=150$		2.10		
Recovered Charge	Q_{rr}	$I_F=15A$		1.20		uC
Peak Reverse Recovery Current	I_{rr}	$V_R=600V$ $-di_F/dt=600A/us$		13.0		A
Reverse Recovery Energy	E_{rec}	$T_{vj}=25$		0.37		mJ
Recovered Charge	Q_{rr}	$I_F=15A$		2.05		uC
Peak Reverse Recovery Current	I_{rr}	$V_R=600V$ $-di_F/dt=600A/us$		12.0		A
Reverse Recovery Energy	E_{rec}	$T_{vj}=125$		0.68		mJ

MG15P12P3



Collector-Emitter Voltage	V_{CES}	$V_{GE}=0V, I_C=1mA, T_{vj}=25$	1200	V
Continuous Collector Current	I_C	$T_C=100$ v_{jmax} 175	15	A
Repetitive Peak Collector Current	I_{CRM}	$t_p=1ms$	30	A
Gate-Emitter Voltage	V_{GES}	$T_{vj}=25$	20	V
Total Power Dissipation	P_{Tot}	$T_C=25$, $T_{vjmax}=175$	155	W

Gate-emitter Threshold Voltage	$V_{GE(th)}$	$V_{GE}=V_{CE}, I_C=0.5mA, T_{vj}=25$	5.2	5.8	6.4	V
Collector-Emitter Cut-off Current	I_{CES}	$V_{CE}=1200V, V_{GE}=0V, T_{vj}=25$			1.0	mA
Collector-Emitter Saturation Voltage	$V_{CE(sat)}$	$I_C=15A, V_{GE}=15V, T_{vj}=25$		1.85	2.25	V
		$I_C=15A, V_{GE}=15V, T_{vj}=125$		2.15		
		$I_C=15A, V_{GE}=15V, T_{vj}=150$		2.25		
Gate Charge	Q_G			0.09		uC
Input Capacitance	C_{ies}	$V_{CE}=25V, V_{GE}=0V,$ $f=1MHz, T_{vj}=25$		1.35		nF
Reverse Transfer Capacitance	C_{res}			0.08		nF
Gate-Emitter leakage current	I_{GES}	$V_{CE}=0V, V_{GE}=20V, T_{vj}=25$			400	nA
Turn-on Delay Time	$t_{d(on)}$	$I_C=15A$ $V_{CE}=600V$ $V_{GE}=\pm 15V$ $R_G=39$ $T_{vj}=25$		46		ns
Rise Time	t_r			45		ns
Turn-off Delay Time	$t_{d(off)}$			182		ns
Fall Time	t_f			168		ns
Energy Dissipation During Turn-on Time	E_{on}			0.92		mJ
Energy Dissipation During Turn-off Time	E_{off}			0.56		mJ



MG15P12P3



Turn

MG15P12P3



Repetitive Peak Reverse Voltage	V_{RRM}	$T_{vj}=25$	1600	V
Average output Current 50/60Hz, sine wave	$I_{F(AV)}$	$T_C=100$	20	A
Maximum RMS Current at Rectifier Output	I_{RMSM}	$T_C=100$	40	A
Surge Forward Current	I_{FSM}	$V_R=0V, t_p=10ms, T_{vj}=45$	270	A
I^2t -value	I^2t	$V_R=0V, t_p=10ms, T_{vj}=45$	360	A^2s

Diode Forward Voltage	V_F	$I_F=15A, T_{vj}=150$	0.96	V
Reverse Current	I_R	$T_{vj}=150, V_R=1600V$	1.0	mA

Rated Resistance	R_{25}		5.0	k	
Deviation of R100	R/R	$T_C=100, R_{100}=493.3$	-5	5	%
Power Dissipation	P_{25}			20.0	mW
B-value	$B_{25/50}$	$R_2=R_{25}\exp[B_{25/50}(1/T_2-1/(298.15 K))]$	3375		K

MG15P12P3



Isolation Voltage	V_{isol}	$t=1\text{min}, f=50\text{Hz}$	2500			V
Maximum Junction Temperature	T_{jmax}				175	
Operating Junction Temperature	T_{jop}		-40		150	
Storage Temperature	T_{stg}		-40		125	
Stray-inductance-module	L_{SCE}			30		

Module lead resistance,
terminals-chip

R_{CC+EE}

$T_C=25$

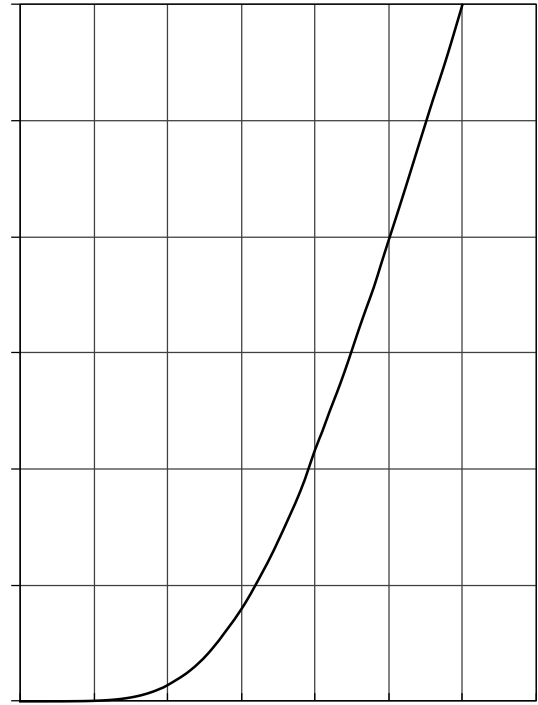
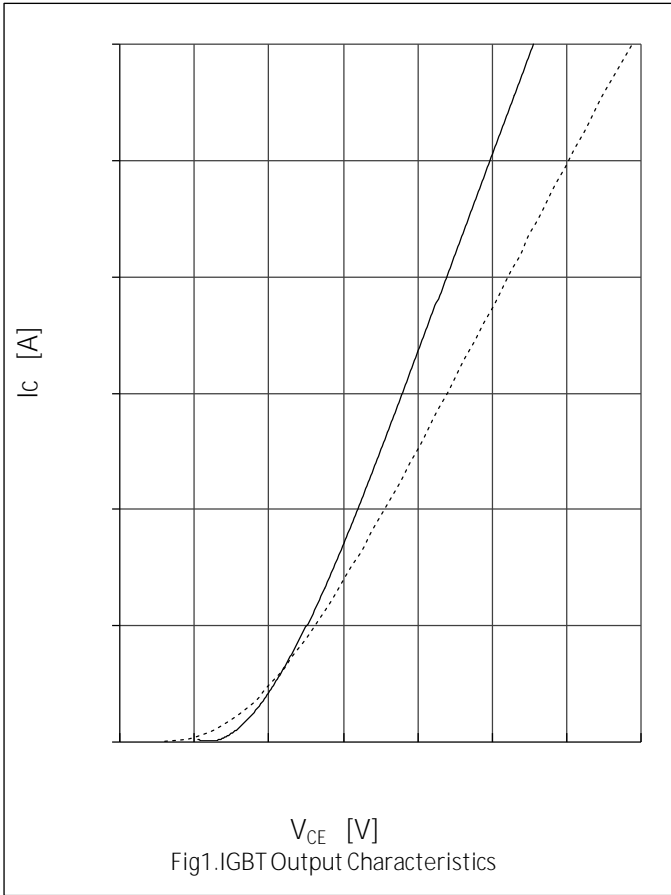

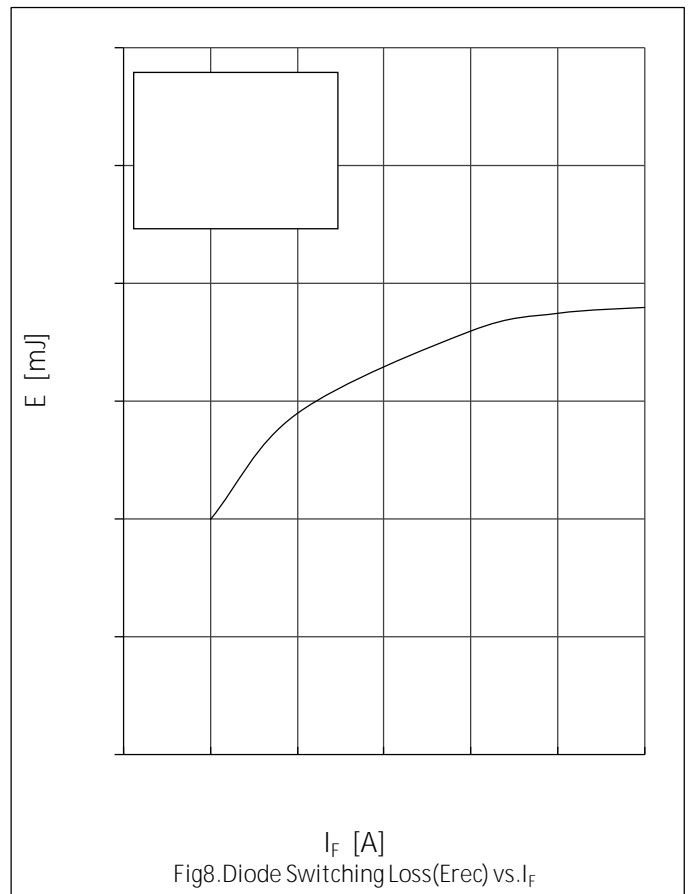
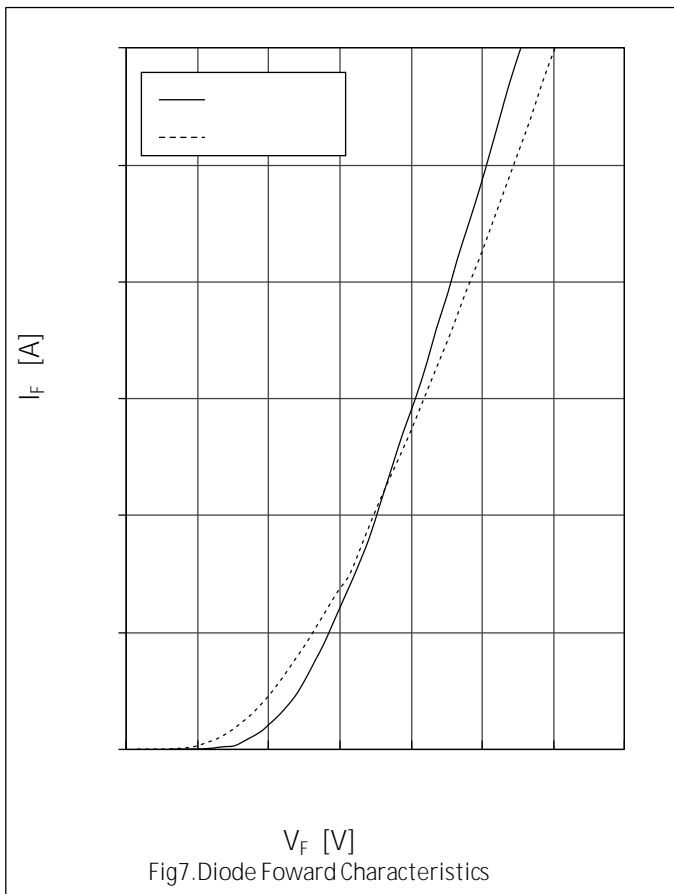
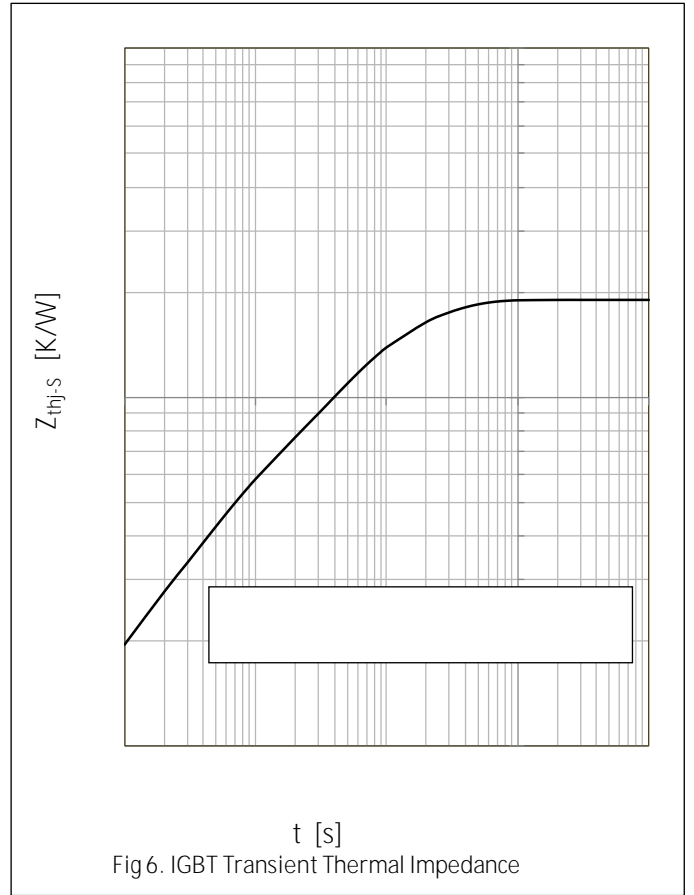
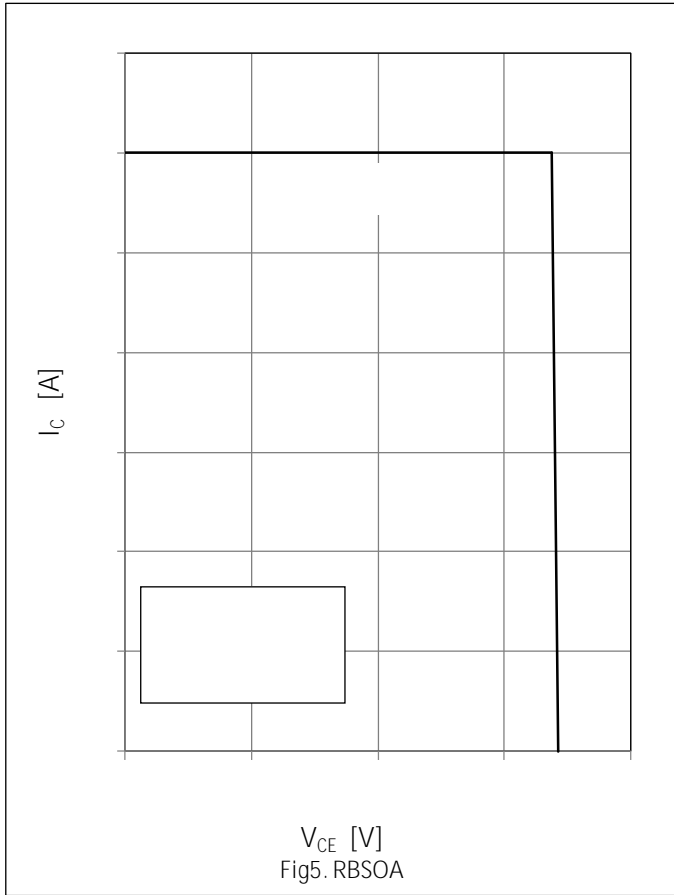

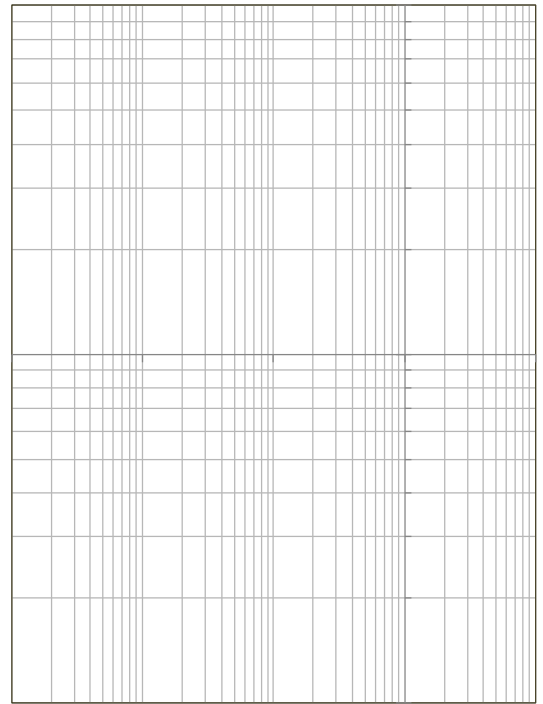
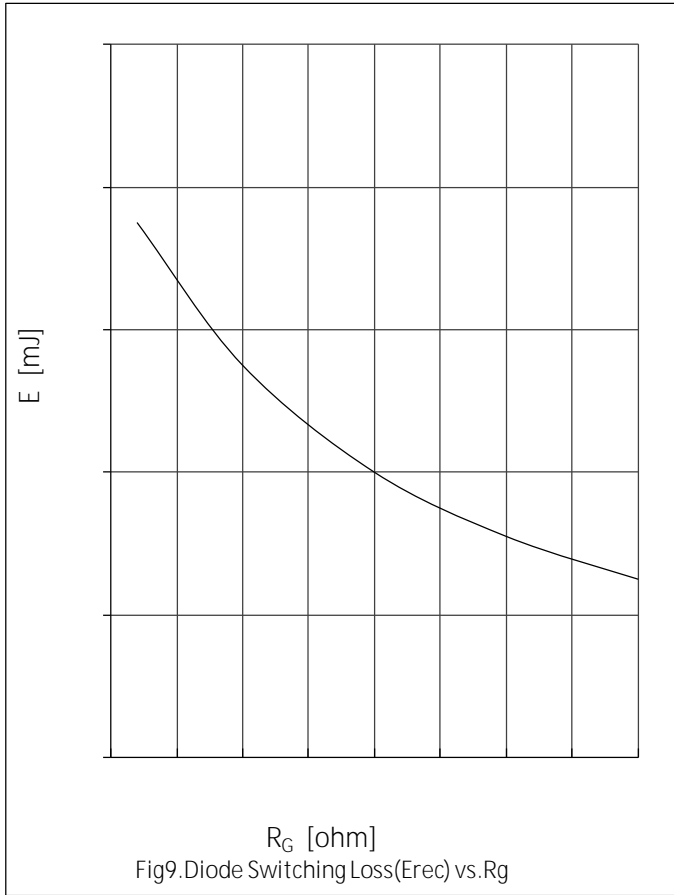

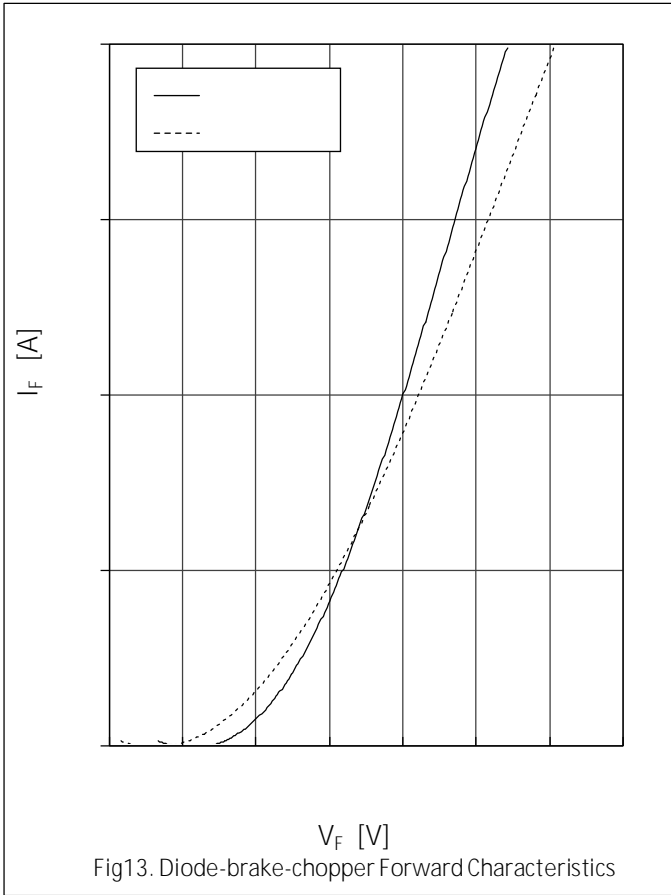



Disclaimer

The information presented in this document is for reference only. Yangzhou Yangjie Electronic Technology Co., Ltd. reserves the right to make changes without notice for the specification of the products displayed herein to improve reliability, function or design or otherwise.

The product listed herein is designed to be used with ordinary electronic equipment or devices, and not designed to be used with equipment or devices which require high level of reliability and the malfunction of with would directly endanger human life (such as aerospace machinery, nuclear-reactor controllers, fuel controllers and other safety devices), Yangjie or anyone on its behalf, assumes no responsibility or liability for any damages resulting from such improper use of sale.

This publication supersedes & replaces all information previously supplied. For additional information, please visit our website [http:// www.frxelec.com](http://www.frxelec.com) , or consult your nearest Yangjie's sales office for further assistance.