

7.0A, 700V,  $R_{DS(on)(T_p)} = 1.2 @V_{GS}=10V$

Low Gate Charge

Low  $C_r$

100% Avalanche Tested

Fast Switching

Improved d/d Capabili

High Frequency Switching Mode Power Supply

Active Power Factor Correction

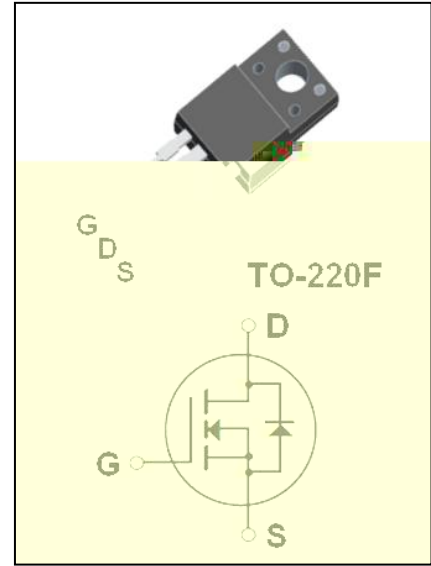

( $T_c=25^\circ\text{C}$  unless otherwise noted)

Symbol	Parameter	Value	Unit
$V_{DSS}$	Drain-Source Voltage	700	V
$I_D$	Drain Current - Continuous ( $T_c=25^\circ\text{C}$ ) - Continuous ( $T_c=100^\circ\text{C}$ )	7.0*	A
		4.5*	A
$I_{DM}$	Drain Current - Pulsed (Note 1)	28*	A
$V_{GSS}$	Gate-Source Voltage	$\pm 30$	V
$E_{AS}$	Single Pulsed Avalanche Energy (Note 2)	590	mJ
$I_{AR}$	Avalanche Current (Note 1)	7.0	A
$E_{AR}$	Repetitive Avalanche Energy (Note 1)	14.0	mJ
d/d	Peak Diode Recovery d/d (Note 3)	4.5	V/n
$P_D$	Power Dissipation ( $T_c=25^\circ\text{C}$ ) - Derate above $25^\circ\text{C}$	48	W
		0.38	W/ $^\circ\text{C}$
$T_j$	Operating Junction Temperature	150	$^\circ\text{C}$
$T_{stg}$	Storage Temperature Range	-55 to +150	$^\circ\text{C}$

Drain Current Limited by Maximum Junction Temperature.

Symbol	Parameter	Max	Unit
$R_{JC}$	Thermal Resistance, Junction to Case	2.6	$^\circ\text{C}/\text{W}$
$R_{JA}$	Thermal Resistance, Junction to Ambient	62.5	$^\circ\text{C}/\text{W}$

(Tc=25°C unless otherwise noted)

Symbol	Parameter	Test Condition	Min	Typ	Max	Unit
$BV_{DSS}$	Drain-Source Breakdown Voltage	$V_{GS}=0V, I_D=250 \mu A$	700	--	--	V
$\frac{\Delta BV_{DSS}}{\Delta T_J}$	Breakdown Voltage Temperature Coefficient	$I_D=250 \mu A$ (Referenced to 25°C)	--	0.7	--	V/°C
$I_{DSS}$	Zero Gate Voltage Drain Current	$V_{DS}=700V, V_{GS}=0V$ $V_{DS}=560V, T_c=125^\circ C$	4	--	1 10 <sup>4</sup>	A
$I_{GSSF}$	Gate-Body Leakage Current, Forward	$V_{GS}=+30V, V_{DS}=0V$	--	--	100	nA
$I_{GSSR}$	Gate-Body Leakage Current, Reverse	$V_{GS}=-30V, V_{DS}=0V$	--	--	-400	nA
$V_{GS(th)}$	Gate Threshold Voltage	$V_{DS}=V_{GS}, I_D=250 \mu A$	2.0 <sup>4</sup>	--	4.0	V
$R_{DS(on)}$	Static Drain-Source On-Resistance	$V_{GS}=10V, I_D=3.5A$ $V_{DS}=40V, I_D=3.5A$ (Note 4)	--	1.2	1.4	$\Omega$
$g_{FS}$	Forward Transconductance		--	6.5	--	S
$C_i$	Input Capacitance		--	1380 <sup>4</sup>	--	pF
$C_o$	Output Capacitance	$V_{DS}=25V, V_{GS}=0V,$ $f=1.0MHz$	--	170	--	pF
$C_r$	Reverse Transfer Capacitance		--	15	--	pF
$t_{d(on)}$	Turn-On Delay Time		4	4	--	ns
$t_r$	Turn-On Rise Time	$V_{DD} = 350V, I_D = 7.0A,$ $R_G = 25 \Omega$ (Note 4,5)	--	100	--	ns
$t_{d(off)}$	Turn-Off Delay Time		4	4	--	ns
$t_f$	Turn-Off Fall Time		--	48	--	ns
$Q_g$	Total Gate Charge	$V_{DS} = 560V, I_D = 7.0A$ (Note D)	4	4	--	ns

ISO 9001:2015 HL

d

T

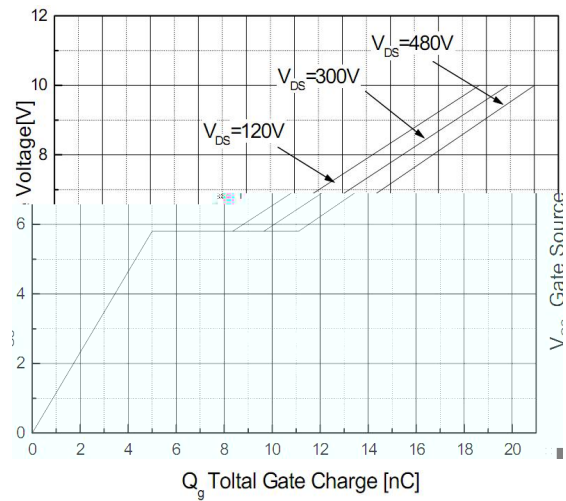
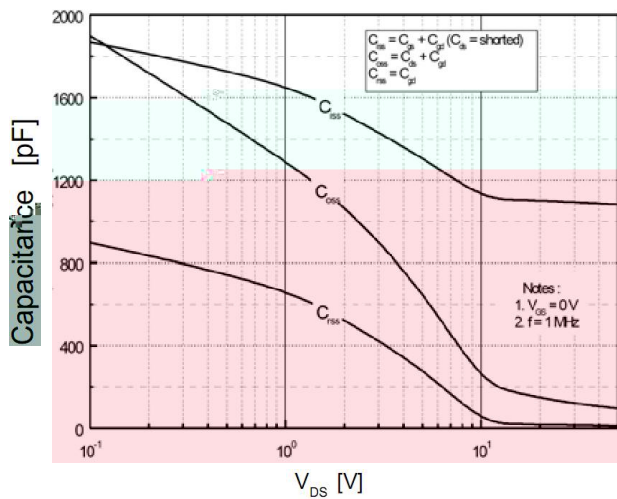
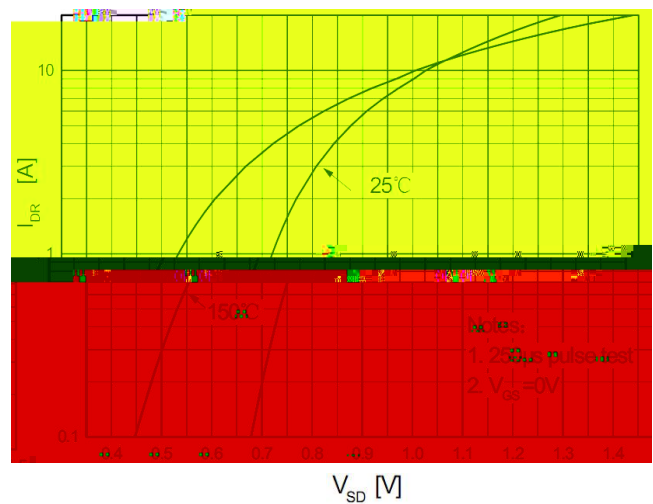
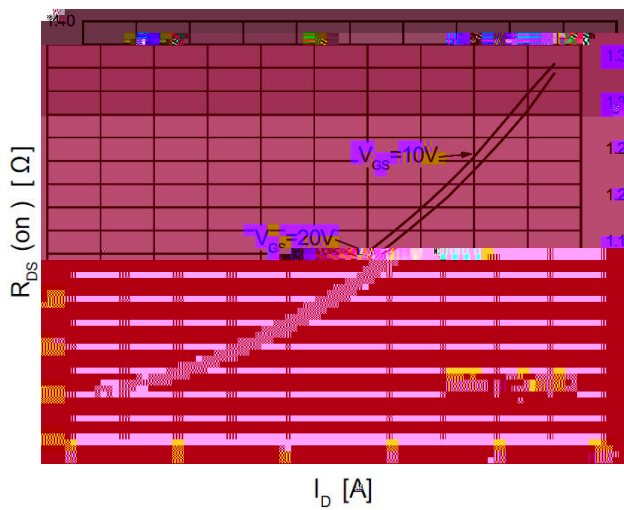
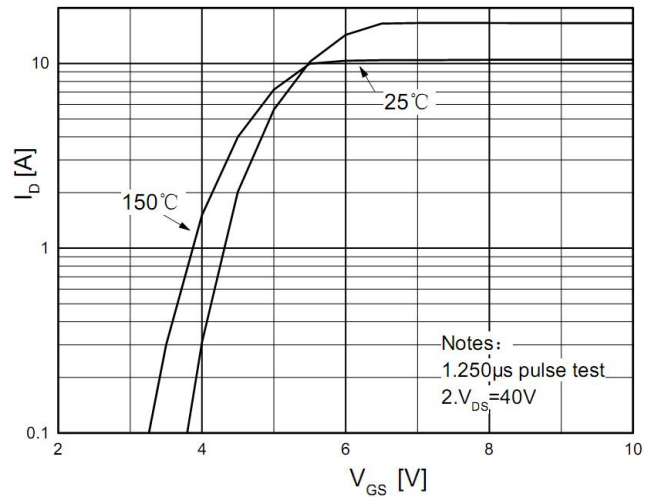
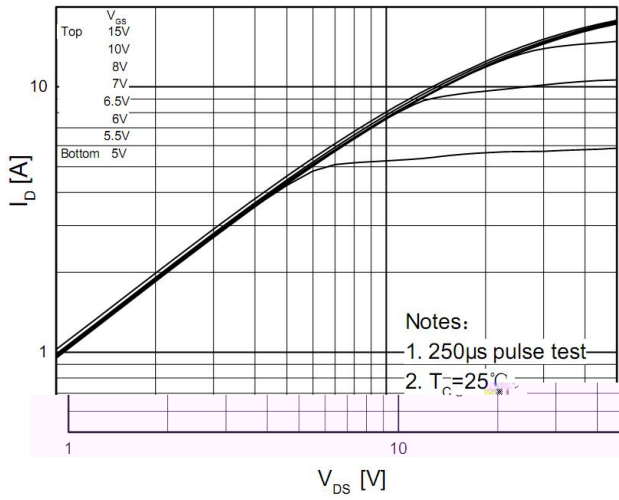

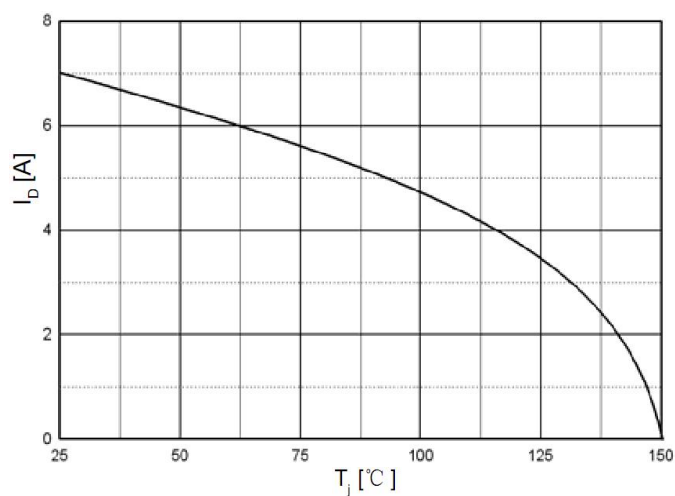
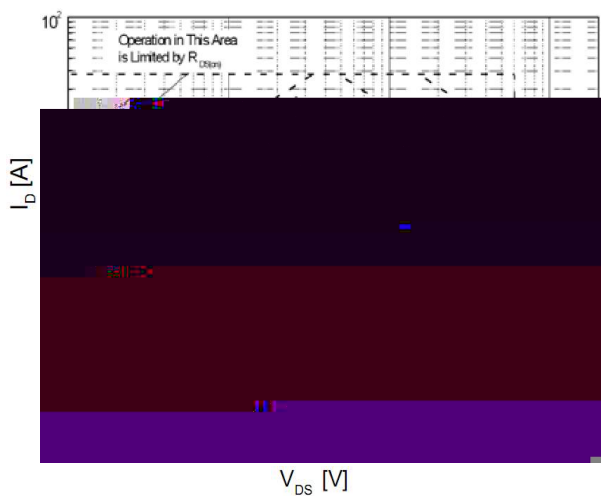
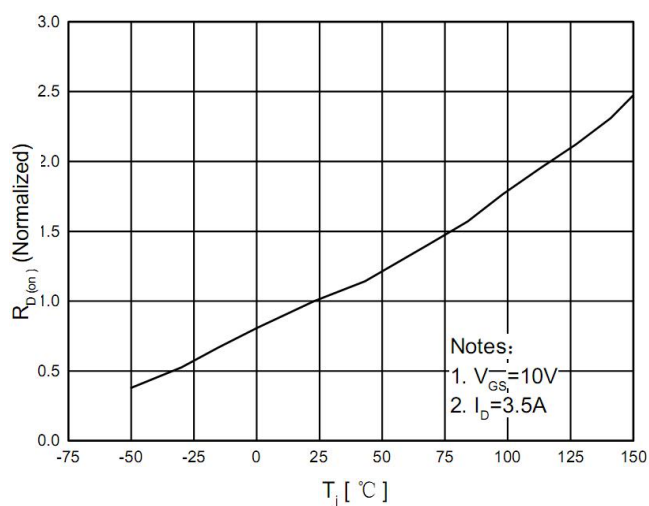
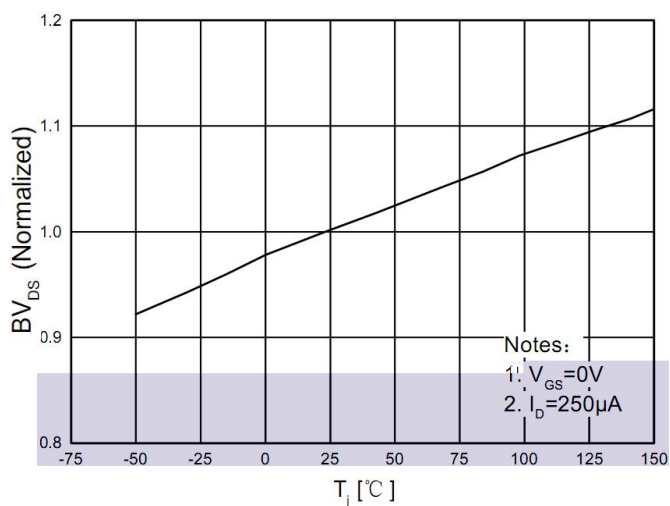

UNIT: mm

SYMBOL	min	nom	ma	SYMBOL	min	nom	ma
A	9.80		10.60	D		2.54	
A1		7.00		D1	1.15		1.55
A2	2.90		3.40	D2	0.60		1.00
A3	9.10		9.90	D3	0.20		0.50
B1	15.40		16.40	E	2.24		2.84
B2	4.35		4.95	E1		0.70	
B3	6.00		7.40	E2		1.0× 45°	
C	3.00		3.70	E3	0.35		0.65
C1	15.00		17.00	E4	2.30		3.30
C2	8.80		10.80			30°	

