

Characteristic values

Parameter	Symbol	Conditions	Value			Unit
			Min.	Typ.	Max.	
Gate-emitter Threshold Voltage	$V_{GE(th)}$	$V_{GE}=V_{CE}, I_C = 3mA, T_{vj}=25$	5.0	6.2	7.0	V
Collector-Emitter Cut-off Current	I_{CES}	$V_{CE}=1200V, V_{GE}=0V, T_{vj}=25$			1.0	mA
Collector-Emitter Saturation Voltage	$V_{CE(sat)}$	$I_C=50A, V_{GE}=15V, T_{vj}=25$		1.85		V
		$I_C=50A, V_{GE}=15V, T_{vj}=125$		2.05		
Input Capacitance	C_{ies}	$V_{CE}=25V, V_{GE} = 0V,$ $f=1MHz, T_{vj}=25$		4.29		nF

Reverse Transfer Capacitance

$C_{Tm0\ g0\ G(C)JTJETQEM/P\ \#CID\ 183/Lang(en-US)BDCqBT/F9\ 6.96\ Tf/GS7\ gs0.750\ w1\ j1\ 0\ 0.489990\ 551.590027\ Tm0\ g0\ G(Tm0\ g0\ G(C)JT$

● Diode

Absolute Maximum Ratings

Parameter	Symbol	Conditions	Value	Unit
Repetitive Peak Reverse Voltage	V_{RRM}	$T_{vj}=25$	1200	V
Continuous DC Forward Current	I_F		50	A
Repetitive Peak Forward Current	I_{FRM}	$t_p=1\text{ms}$	100	A

Characteristic values

Parameter	Symbol	Conditions	Value			Unit
			Min.	Typ.	Max.	
Forward Voltage	V_F	$I_F=50\text{A}, T_{vj}=25$		1.95	2.20	V
		$I_F=50\text{A}, T_{vj}=125$		2.05		
Recovered Charge	Q_{rr}	$I_F = 50\text{ A}$		2.77		uC

Peak Reverse Recovery/GS7 gs0.750 w1 j1 0 0 1 4 G1 j1 0 0 BDCqBT/F9 10.56 Tf/GS7 gs0.750 w1 j1 0 0 1 451.299988 461648999098T
 $V_R=600\text{V}$
 $-di_F/dt = 800\text{A/us}$
 $T_{vj}=25$



● Module Characteristics

T_C=25°C unless otherwise specified

Parameter	Symbol
-----------	--------

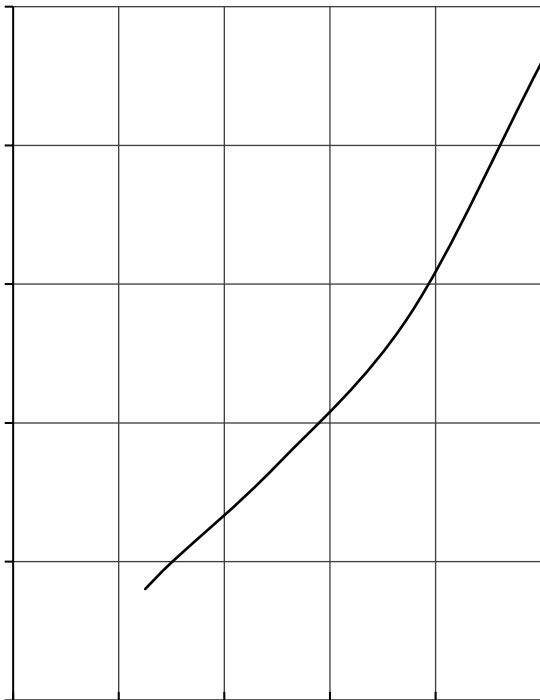
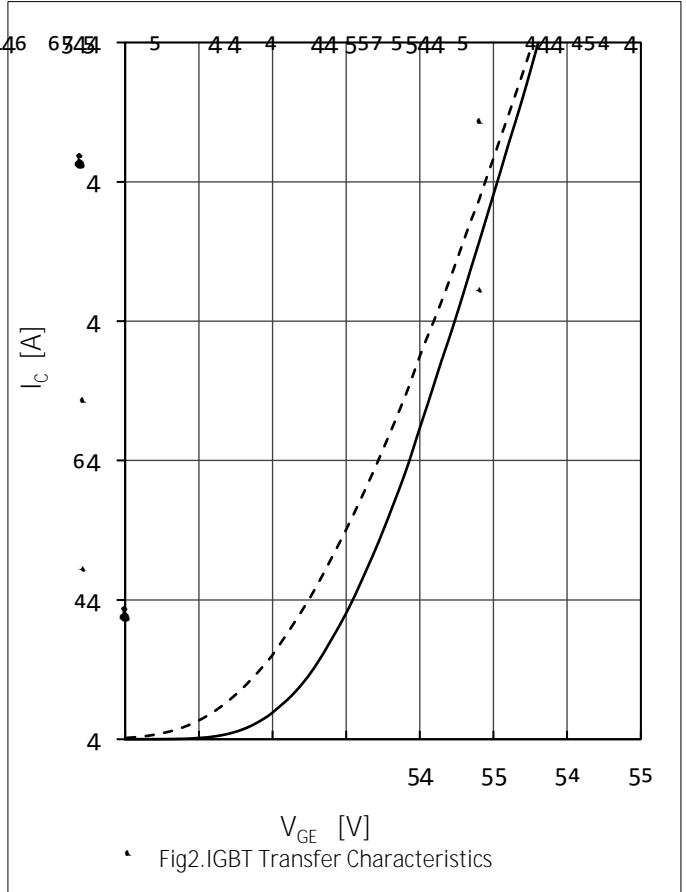
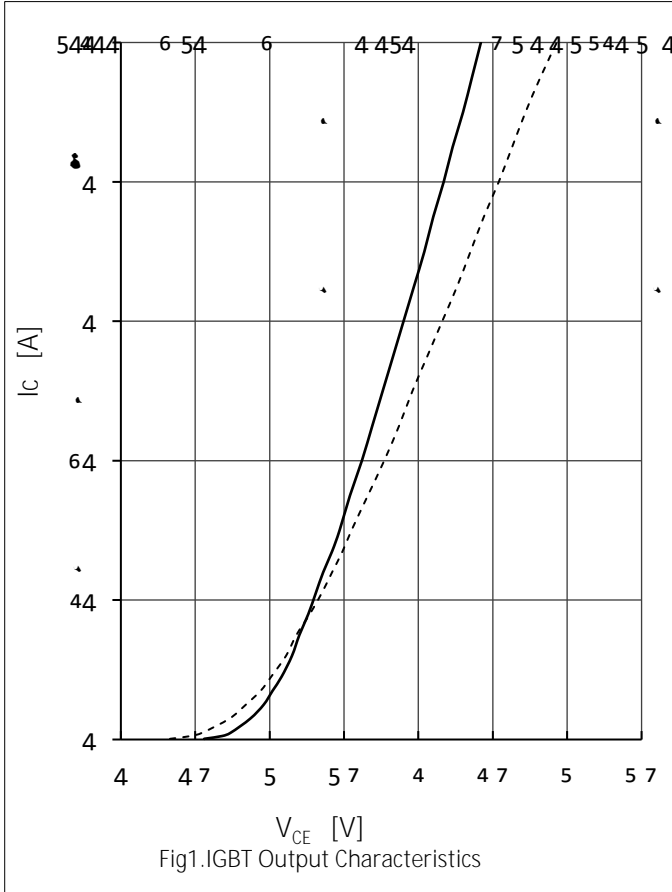

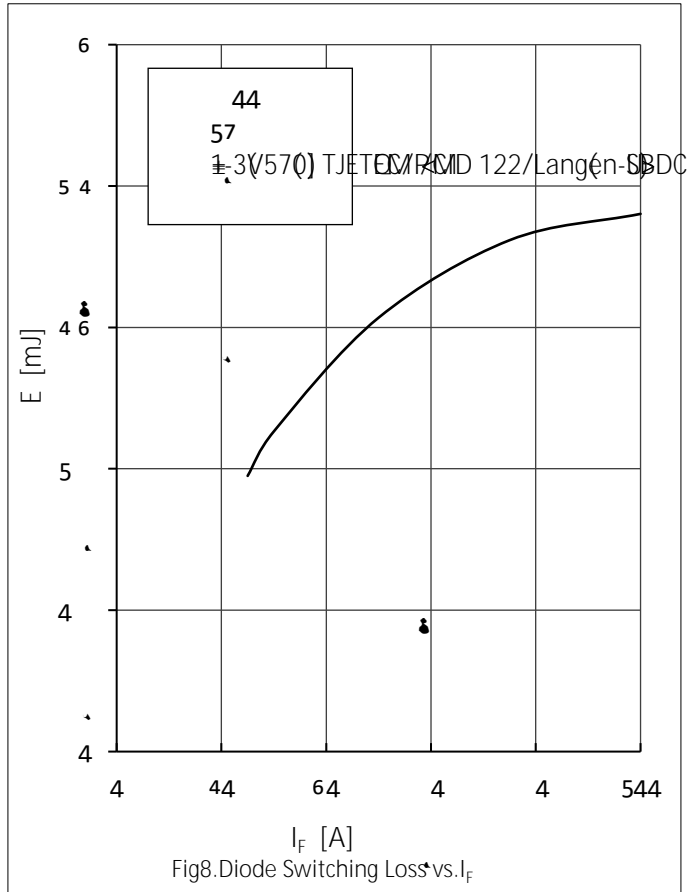
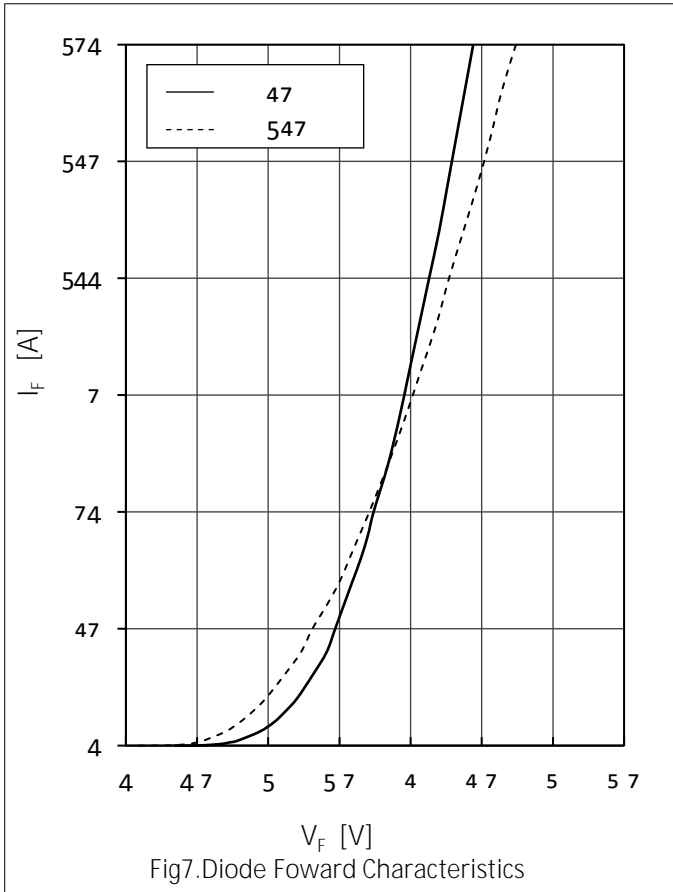
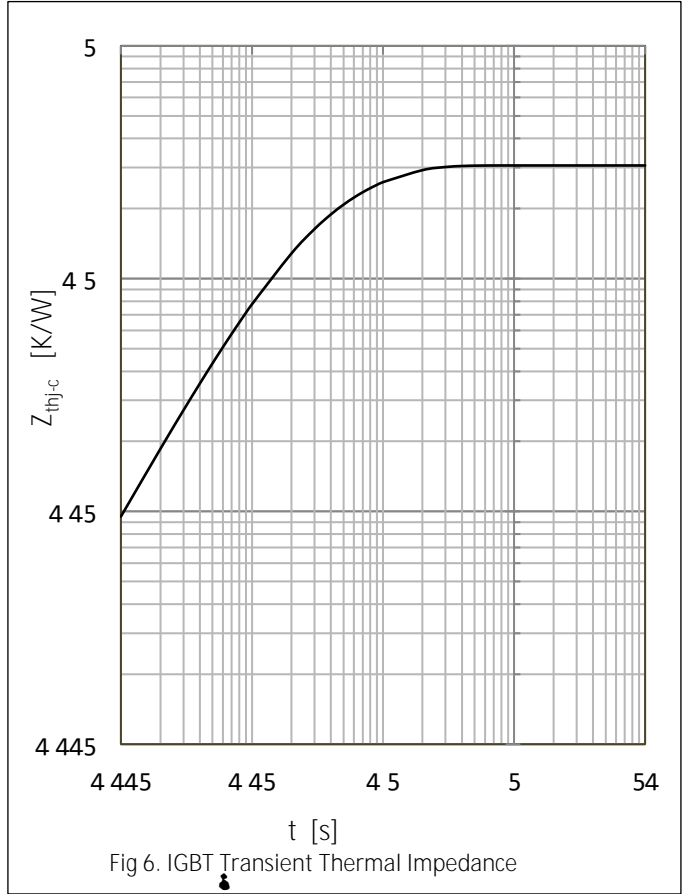
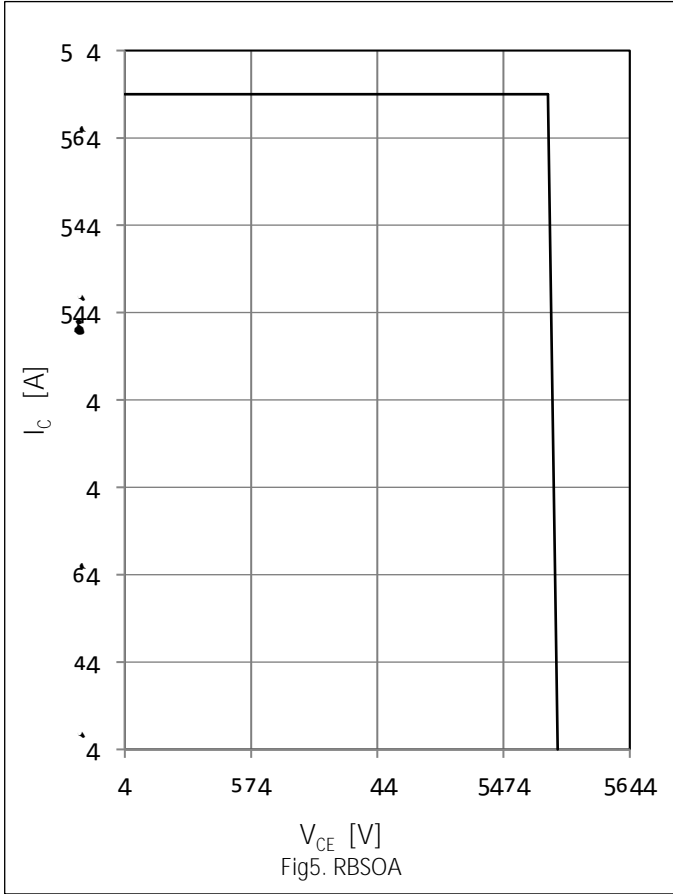

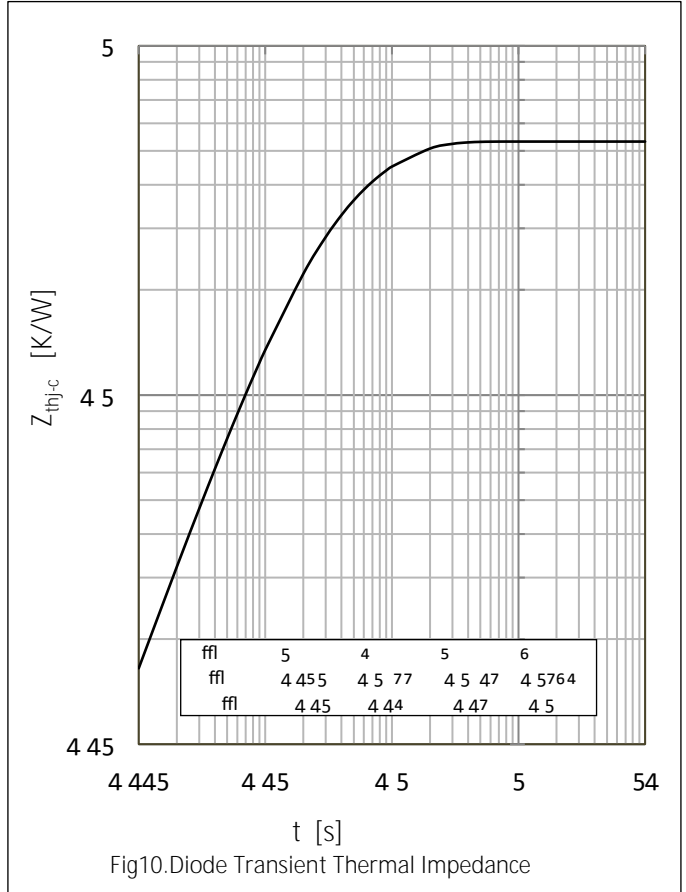
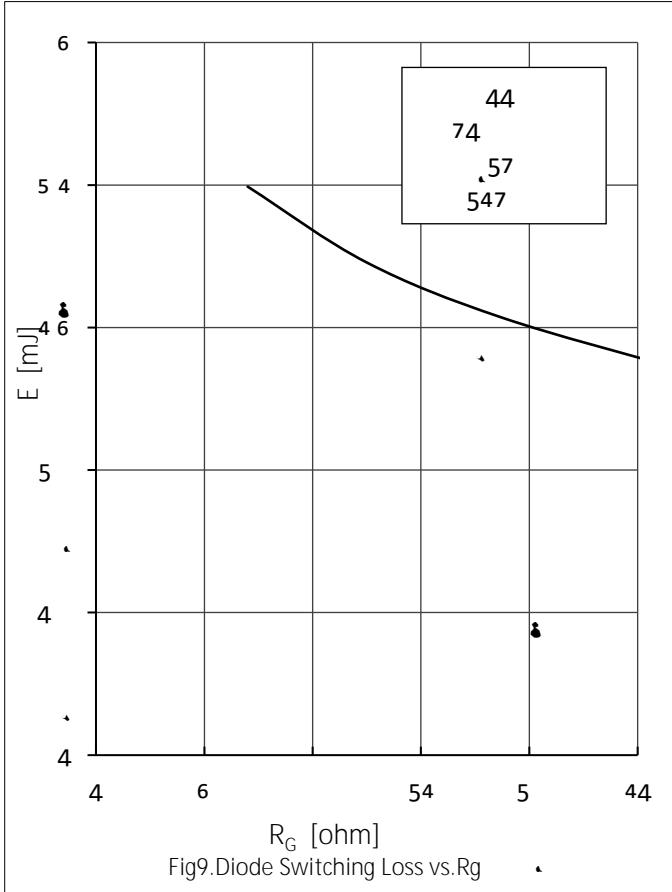



● Circuit Diagram

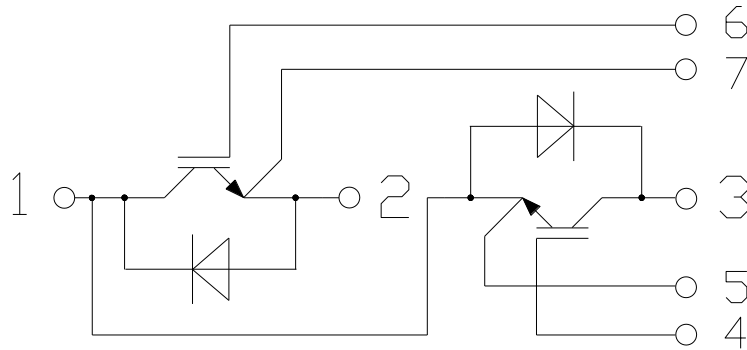

● Package Outline Information

Dimensions in Millimeters

