

IGBT Modules

V _{CES}	1200V
I _C	50A

Applications

- Inverter for motor drive
- AC and DC servo drive amplifier
- UPS (Uninterruptible Power Supplies)
- Soft switching welding machine

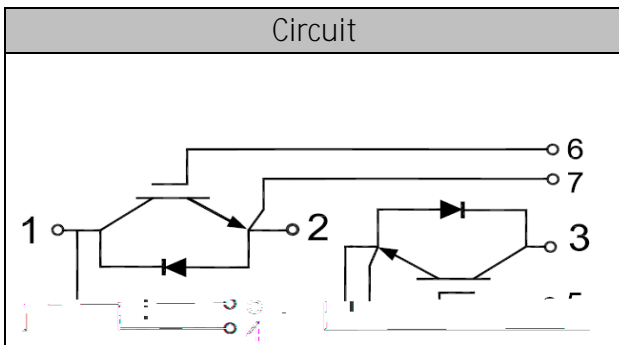

Features

- Low V_{ce(sat)} with Trench technology
- V_{ce(sat)} with positive temperature coefficient
- High short circuit capability(10us)
- Including ultra fast & soft recovery anti-parallel FWD
- Low inductance
- Maximum junction temperature 175

● IGBT

Absolute Maximum Ratings

Parameter	Symbol	Conditions	Value	Unit
Collector-Emitter Voltage	V _{CES}	V _{GE} =0V, I _C =1mA, T _{vj} =25	1200	V
Continuous Collector Current	I _C	T _c =100	50	A
Repetitive Peak Collector Current	I _{CRM}	t _p =1ms	100	A
Gate-Emitter Voltage	V _{GES}	T _{vj} =25	20	V
Total Power Dissipation	P _{tot}	T _c =25 T _{vjmax} =175	485	W

**Characteristic values**

Parameter	Symbol	Conditions	Value			Unit
			Min.	Typ.	Max.	
Gate-emitter Threshold Voltage	$V_{GE(th)}$	$V_{GE}=V_{CE}, I_C=3mA, T_{vj}=25$	5.0	6.2	7.0	V
Collector-Emitter Cut-off Current	I_{CES}	$V_{CE}=1200V, V_{GE}=0V, T_{vj}=25$			1.0	mA
Collector-Emitter Saturation Voltage	$V_{CE(sat)}$	$I_C=50A, V_{GE}=15V, T_{vj}=25$		1.85		V
		$I_C=50A, V_{GE}=15V, T_{vj}=125$		2.05		
Input Capacitance	C_{ies}	$V_{CE}=25V, V_{GE}=0V,$ $f=1MHz, T_{vj}=25$		4.29		nF
Reverse Transfer Capacitance	C_{res}				0.20	
Gate-Emitter leakage current	I_{GES}	$V_{CE}=0V, V_{GE}=20V, T_{vj}=25$			400	nA
Turn-on Delay Time	$t_{d(on)}$			150		ns
Rise Time	t_r			75		ns

$I_C=50A$
 $V_{CE}=600V$
 $V_{GE}=\pm 15V$
 $R_G=15$
 $T_{vj}=25$



● Diode

Absolute Maximum Ratings

Parameter	Symbol	Conditions	Value	Unit
Repetitive Peak Reverse Voltage	V_{RRM}	$T_{vj}=25$	1200	V
Continuous DC Forward Current	I_F		50	A
Repetitive Peak Forward Current	I_{FRM}	$t_p=1\text{ms}$	100	A

Characteristic values

Parameter	Symbol	Conditions	Value			Unit
			Min.	Typ.	Max.	
Forward Voltage	V_F	$I_F=50\text{A}, T_{vj}=25$		1.95	2.20	V
		$I_F=50\text{A}, T_{vj}=125$		2.05		
Recovered Charge	Q_{rr}	$I_F=50\text{A}$		2.77		μC
Peak Reverse Recovery Current	I_{rr}	$V_R=600\text{V}$ $-di_F/dt=800\text{A}/\mu\text{s}$		30		A
Reverse Recovery Energy	E_{rec}	$T_{vj}=25$		0.65		mJ
Recovered Charge	Q_{rr}	$I_F=50\text{A}$		6.39		μC
Peak Reverse Recovery Current	I_{rr}	$V_R=600\text{V}$ $-di_F/dt=800\text{A}/\mu\text{s}$		31		A
Reverse Recovery Energy	E_{rec}	$T_{vj}=125$		2.16		mJ



● Module Characteristics

$T_C=25^{\circ}\text{C}$ unless otherwise specified

Parameter	Symbol	Conditions	Value			Unit
			Min.	Typ.	Max.	
Isolation voltage	V_{isol}	$t=1\text{min}, f=50\text{Hz}$	2500			V
Maximum Junction Temperature	T_{jmax}				175	
Operating Junction Temperature	T_{vjop}		-40		150	
Storage Temperature	T_{stg}		-40		125	
Thermal Resistance Junction-to Case	R_{JC}	per IGBT			0.31	K/W
		per Diode			0.57	
Thermal Resistance Case-to Sink	R_{CS}	Conductive grease applied		0.05		K/W
Module Electrodes Torque	M_t	Recommended(M5)	2.5		5.0	N·m
Module-to-Sink Torque	M_s	Recommended(M6)	3.0		5.0	N·m
Weight of Module	G			150		g



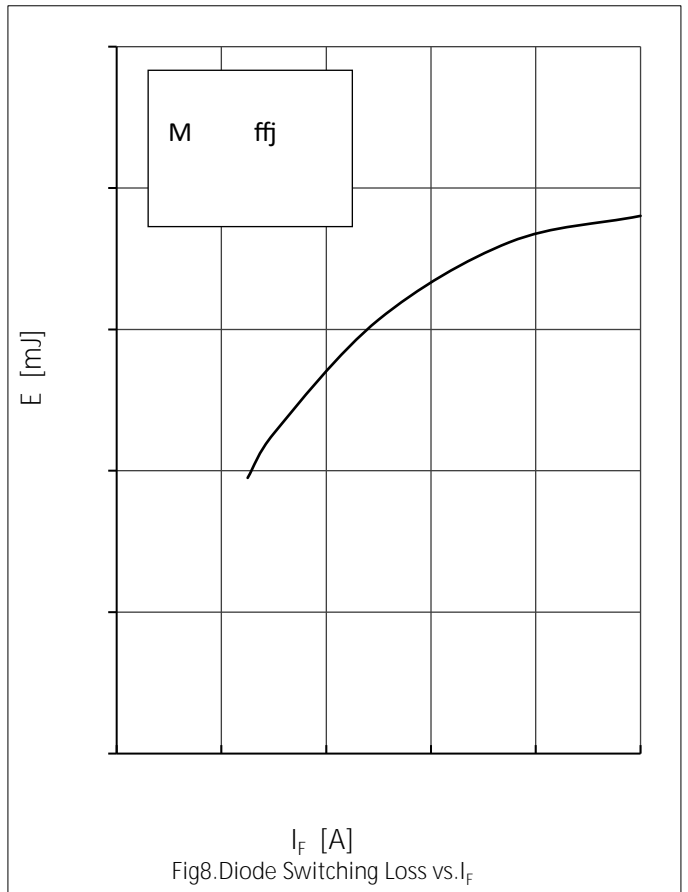
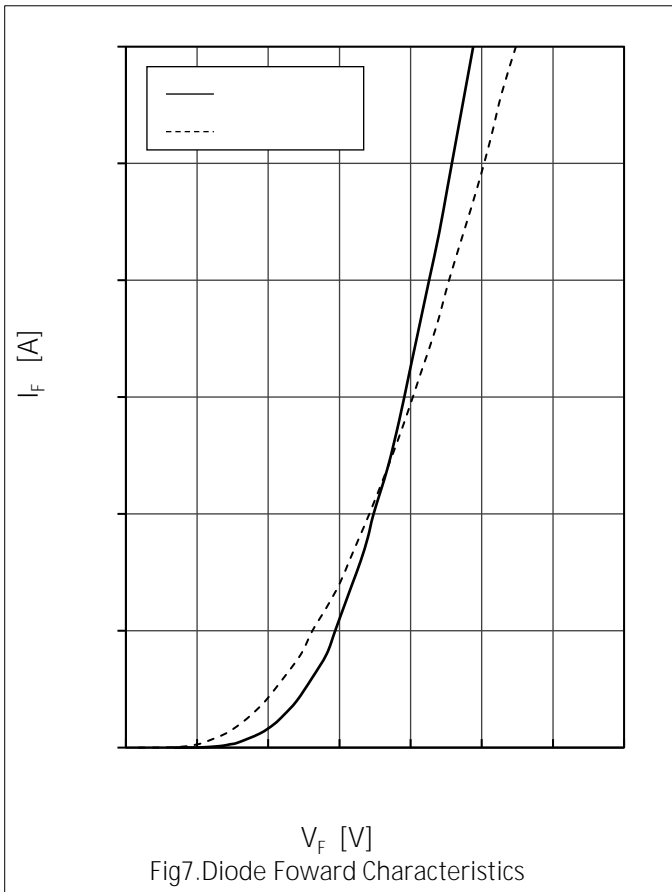
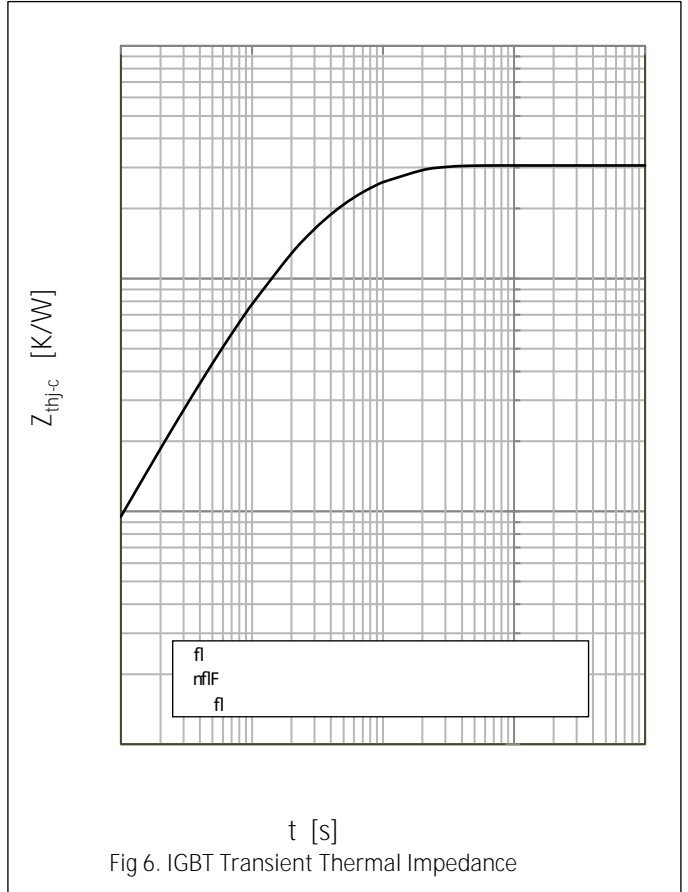
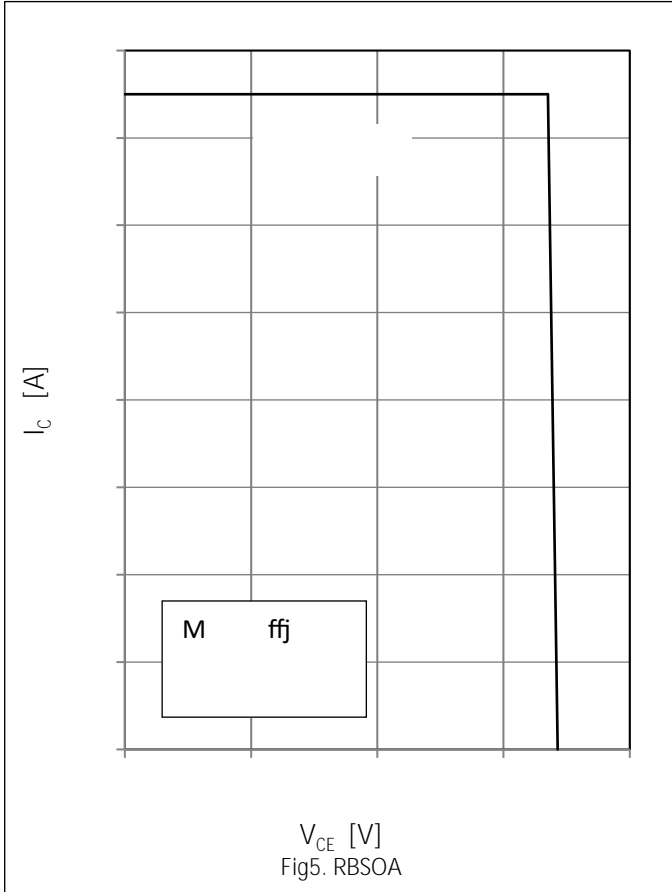



MG50HF12TLC1 **RoHS** COMPLIANT



● Circuit Diagram

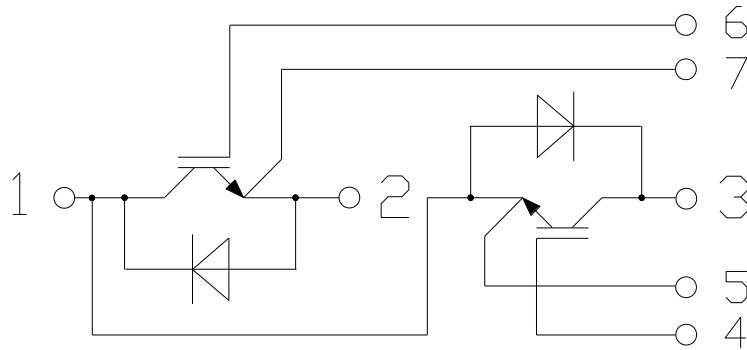

● Package Outline Information

Dimensions in Millimeters

