



TD101X Series

LSOP4, DC Input, Photo Transistor Coupler

Description

The TD101X series combine an AlGaAs infrared emitting diode as the emitter which is optically coupled to a silicon planar phototransistor detector in a plastic LSOP4 package with the robust coplanar double mold structure. TD101X series provide the most stable isolation feature.

Features

- High isolation (000) * +S
- Temperature stability available see order information
- DC input with transistor output
- Operating temperature range . ((/ , to 110 / ,
- $I_{S0} \leq 1A$, ' , compliance
- +SL class 1
- Regulatory Approvals
 - 2L . 2L1(33)
 -)D1 . 14503!3.(. (6)D1077!. (8
 - , 9 , : G ; !< !=#1% G ; 77<7

Applications

- Switch mode power supplies
- Programmable controllers
- Household appliances
- Office equipment

SCHEMATIC

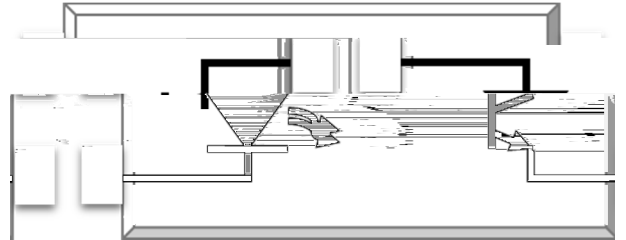

PIN DEFINITION

1. Anode
2. Cathode
3. Emitter
4. Collector

PACKAGE OUTLINE

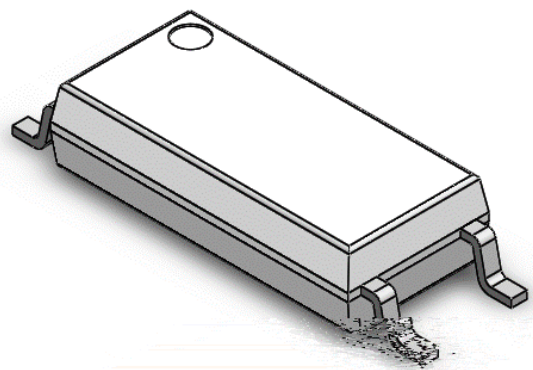



TD101X Series

LSOP4, DC Input, Photo Transistor Coupler

ABSOLUTE MAXIMUM RATINGS

A * A+ 1T1 *	S@+ ; OL)AL21	24AT	4OT1
A4 2T				
Borward , urrent	A _B	50	mA	
ea" Borward , urrent	A _B	1	A	1
* e&erse)oltage)*	5)	
Anput ower Dissipation	A	100	m\$	
O2T 2T				
, ollector . 1mitter)oltage),1o	70)	
1mitter . , ollector)oltage)1,o	3)	
, ollector , urrent	A,	(0	mA	
Output ower Dissipation	o	1(0	m\$	
, O+ +O4				
Total ower Dissipation	tot	?(0	m\$	
Asolation)oltage)iso	(000)rms	?
Operating Temperature	Topr	.((C110	/,	
Storage Temperature	Tstg	.((C1?(/,	
Soldering Temperature	Tsol	?50	/,	



TD101X Series

LSOP4, DC Input, Photo Transistor Coupler

ELECTRICAL OPTICAL CHARACTERISTICS at Ta=25°C							
A * A+1T1 *	S@+ ; OL	+A4#	T@ #	+AX#	24AT	T1ST , O4DATAO4	4OT1
A4 2T							
Forward Voltage	V _B	.	1#!	1#5)	V _{BD} (0mA	
Reverse Current	I _{A*}	.	.	10	EA) *D5)	
Input Capacitance	C _{in}	.	=0	? (0	pB) D0% fD1 " ' F	
O2T 2T							
Collector Dark Current	I _{A,10}	.	.	100	nA) , 1D?0) % A _B D0	
Collector Emitter Saturation Voltage	V _{CE(sat)}	70	.	.)	V _{CE(sat)} @ I _C =1mA % A _B D0	
Emitter Saturation Voltage	V _{BE(sat)}	3	.	.)	V _{BE(sat)} @ I _E =1mA % A _B D0	
T * A4SB1 * , ' A * A , T1 * ASTA , S							
Current Transfer Ratio	TD1010	T *	=00	.	500	G	V _{BD} (mA%) , 1D()
	TD101((0	.	1(0		
	TD1015		100	.	=00		
	TD1013		70	.	150		
	TD1017		1=0	.	?50		
	TD101<		?00	.	!00		V _{BD} 10mA%) , 1D()
	TD1011		50	.	=00		
	TD101?		5=	.	1?(
	TD101=		100	.	?00		
	TD101!		150	.	=?0		
	TD101?		??	.	.		
	TD101=		=!	.	.		
TD101!	(5	.	.				
Collector Emitter Saturation Voltage	V _{CE(sat)}	.	0#1	0#=)	V _{CE(sat)} @ I _C =1mA % A _B D10mA % A _B D1mA	
Isolation Resistance	R _{ISO}	10H1?	10H1!	.	I	D , (00) % !0 C 50G * # ' #	
Bloating Capacitance	C _{AO}	.	0#!	1	pB) D0% fD1 + ' F	
Turn-off Frequency	f _{BC}	.	70	.	" ' F) , 1D?) % A _B D?mA * L D100 I % . = d ;	=
Rise Time	t _r	.	(17	Es) , 1D?) % A _B D?mA	!
Fall Time	t _f	.	5	17	Es	* L D100 I	!



TD101X Series

LSOP4, DC Input, Photo Transistor Coupler

CHARACTERISTIC CURVES

Fig.1 Forward Current vs. Ambient Temperature

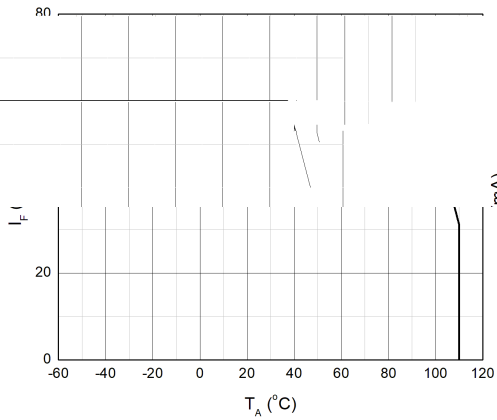

Fig.2 Collector Power Dissipation vs. Ambient Temperature

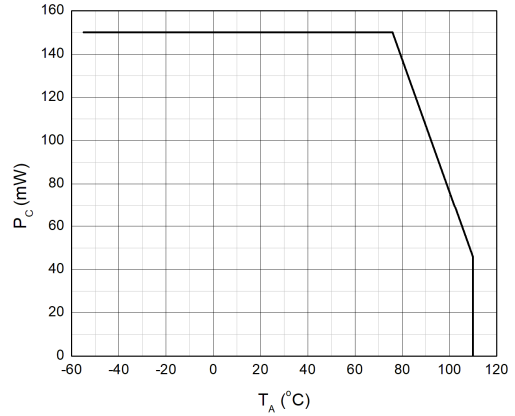

Fig.3 Forward Current vs. Forward Voltage

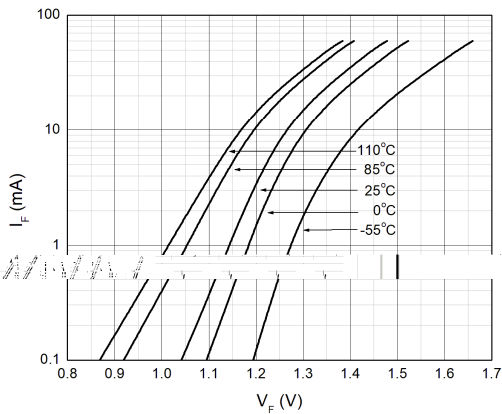

Fig.4 Collector Dark Current vs. Ambient Temperature

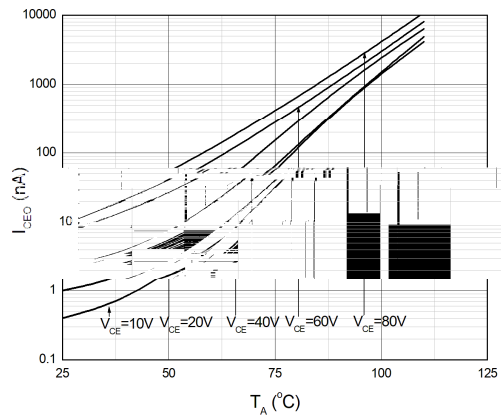

Fig.5 Collector Current vs. Collector-emitter Voltage

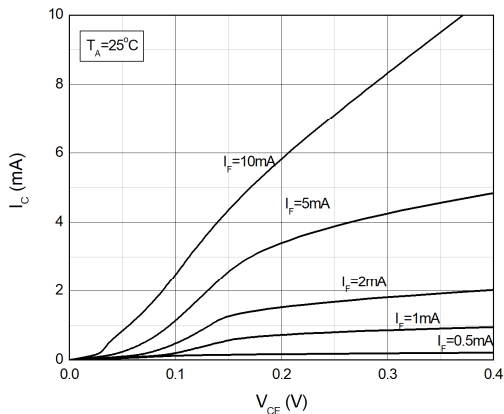
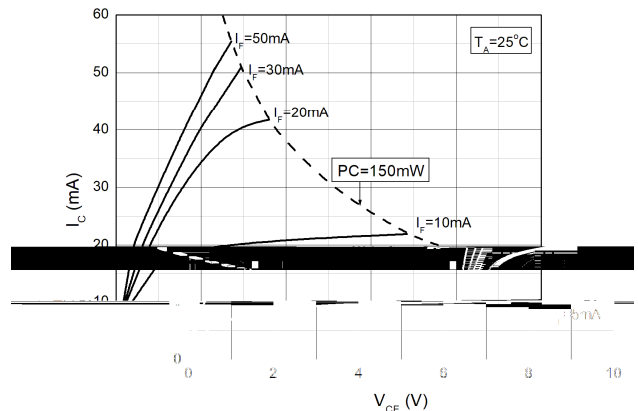

Fig.6 Collector Current vs. Collector-emitter Voltage





TD101X Series

LSOP4, DC Input, Photo Transistor Coupler

CHARACTERISTIC CURVES

Fig.7 Normalized Current Transfer Ratio vs. Forward Current

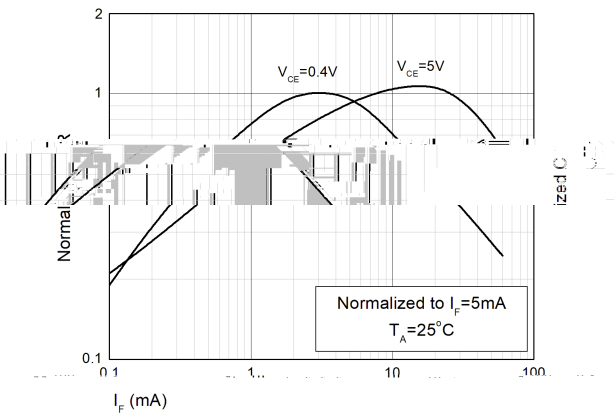

Fig.8 Normalized Current Transfer Ratio vs. Ambient Temperature

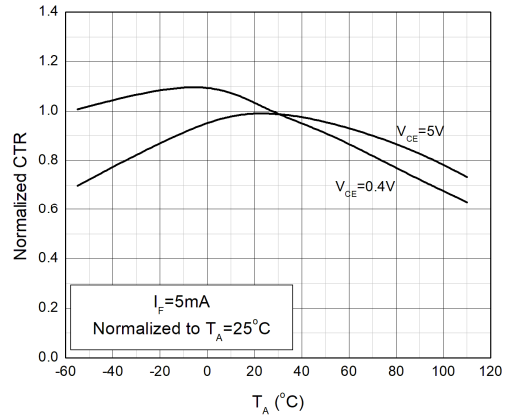

Fig.9 Collector-emitter Saturation Voltage vs. Ambient Temperature

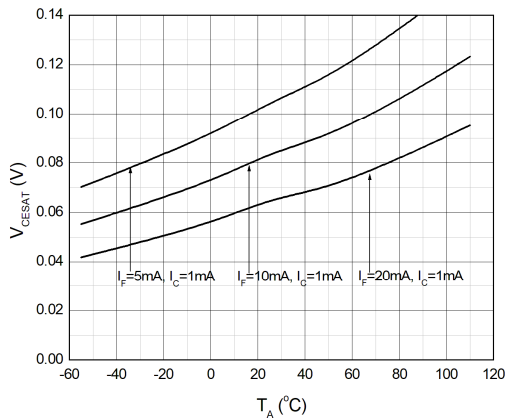

Fig.10 Switching Time vs. Load Resistance

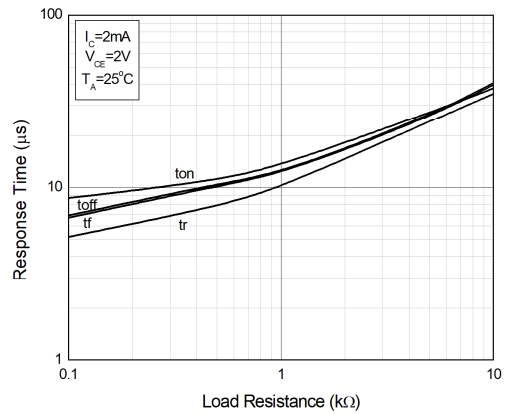
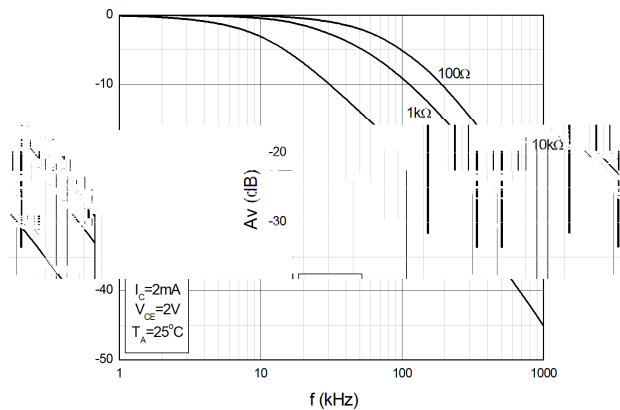

Fig.11 Frequency Response





TD101X Series

LSOP4, DC Input, Photo Transistor Coupler

TEST CIRCUITS

Fig.12 Test Circuits of Response Time

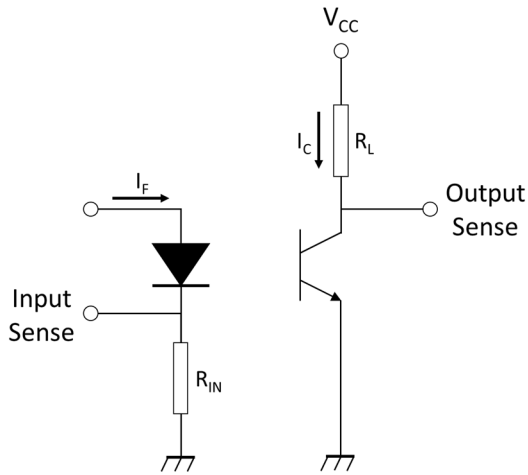

Fig.13 Curves of Response Time

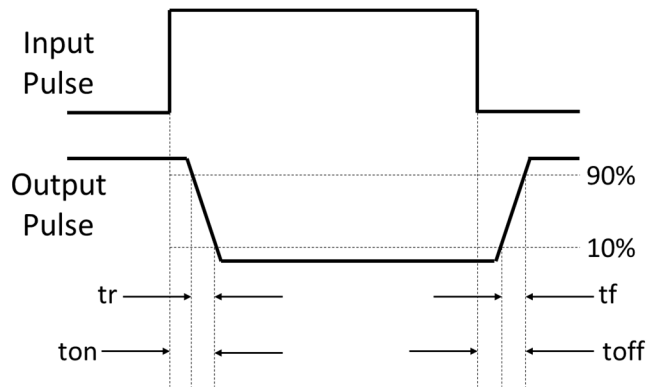
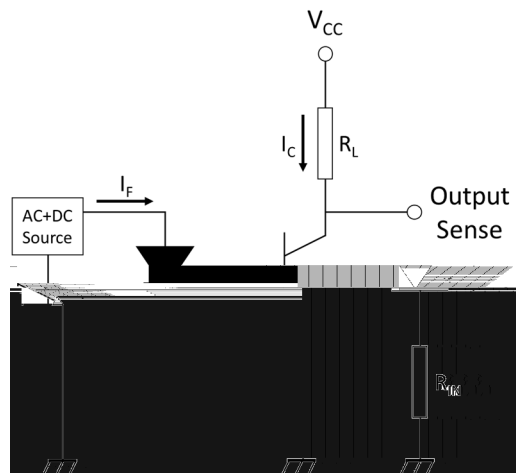

Fig.14 Test Circuits of Frequency Response





TD101X Series

LSOP4, DC Input, Photo Transistor Coupler

PACKAGE DIMENSIONS (Dimensions in mm unless otherwise stated)

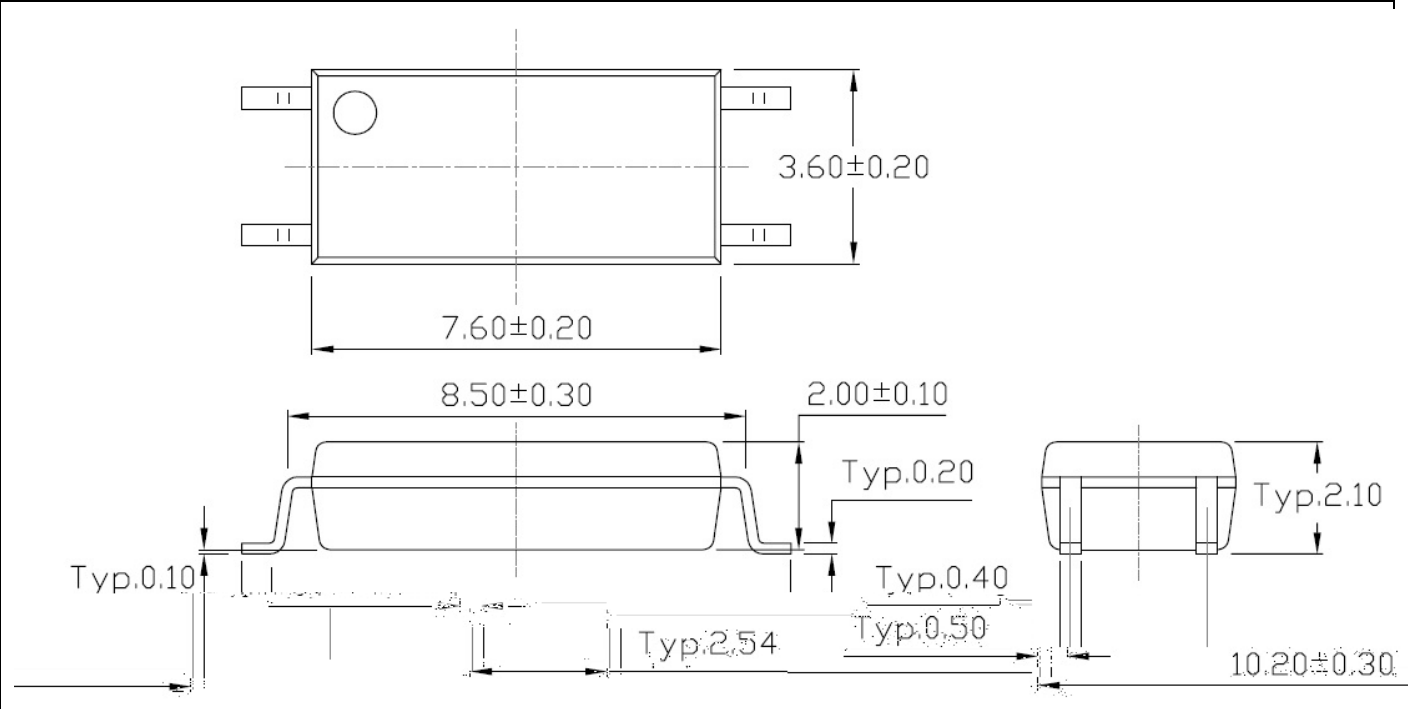

RECOMMENDED SOLDER MASK (Dimensions in mm unless otherwise stated)

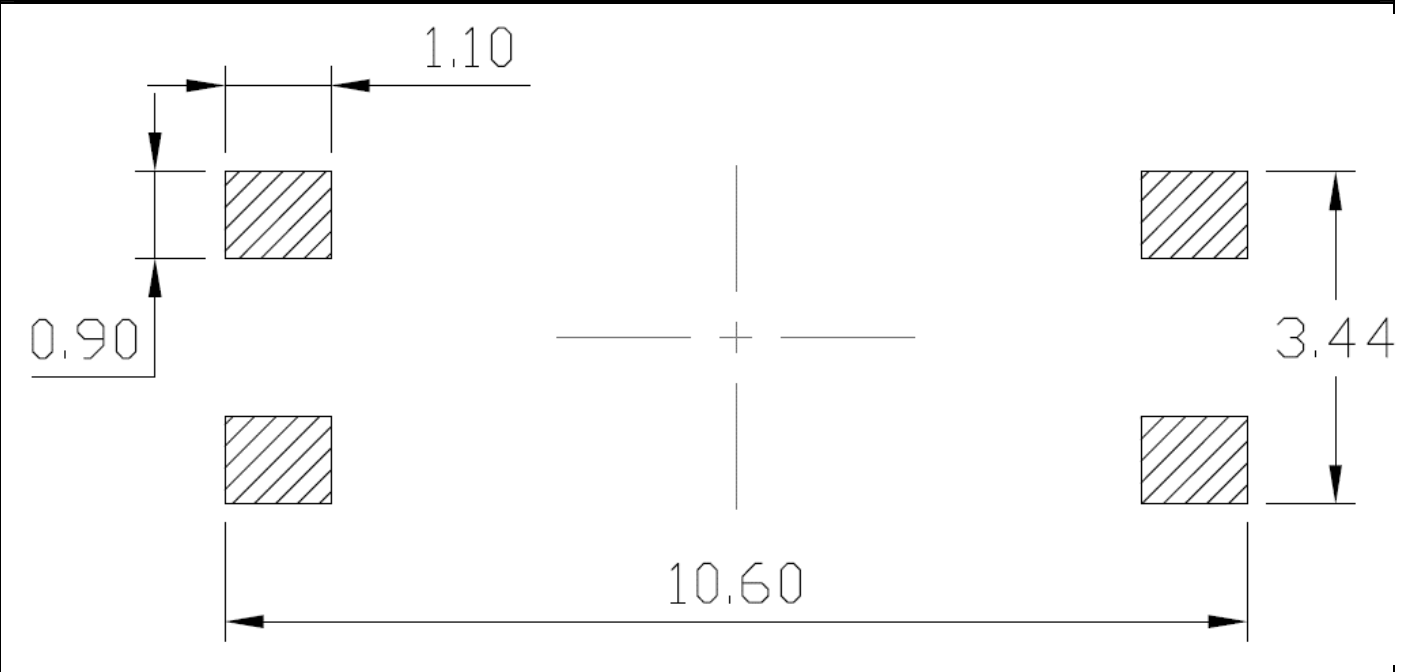



TD101X Series

LSOP4, DC Input, Photo Transistor Coupler

CARRIER TAPE SPECIFICATIONS (Dimensions in mm unless otherwise stated)

Option T1

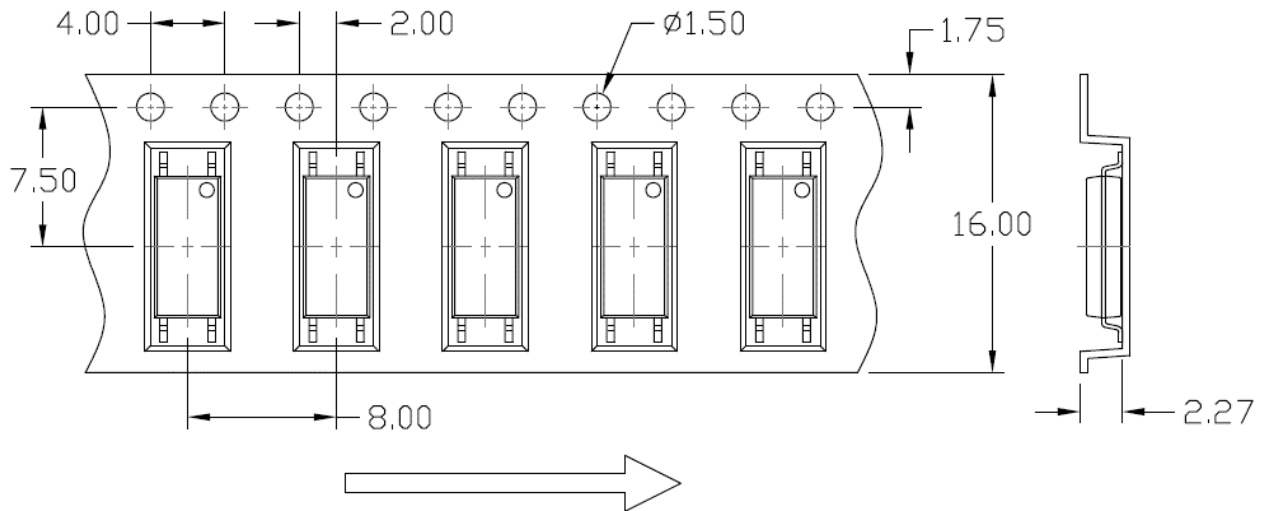

Option T2

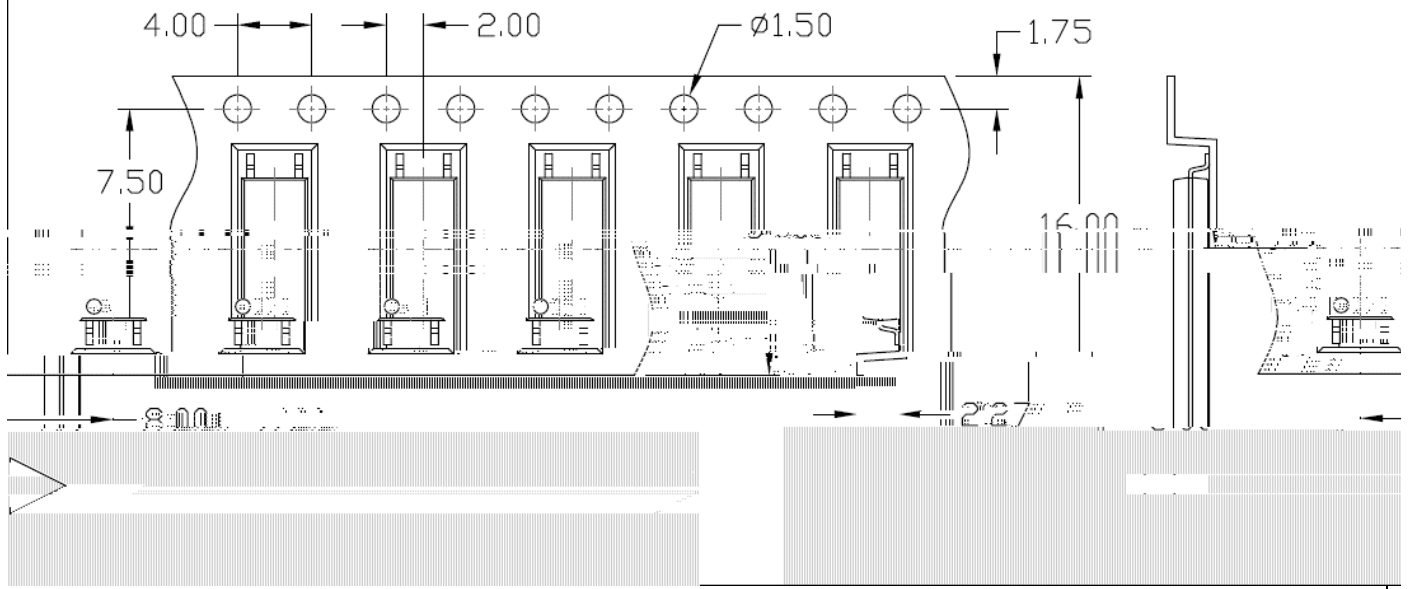



TD101X Series

LSOP4, DC Input, Photo Transistor Coupler

REEL SPECIFICATIONS (Dimensions in mm unless otherwise stated)

Option T1 & T2

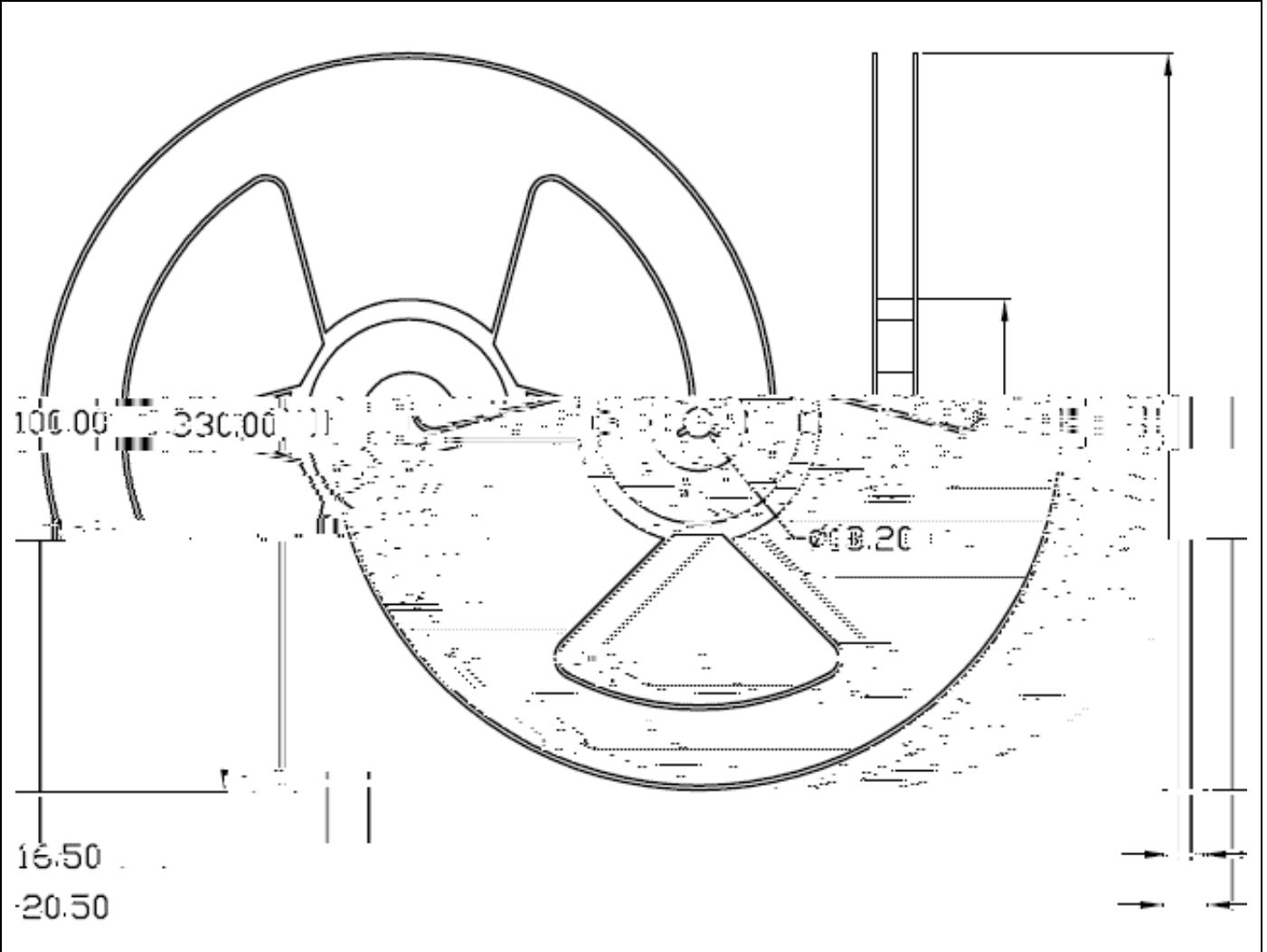



TD101X Series

LSOP4, DC Input, Photo Transistor Coupler

BOX SPECIFICATIONS (Reel Type)

Inner Box



TD101X Series

LSOP4, DC Input, Photo Transistor Coupler

ORDERING AND MARKING INFORMATION

MARKING INFORMATION

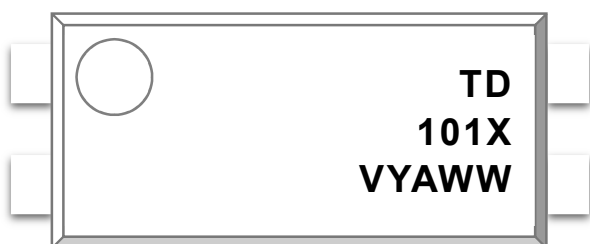

TD : Company Abbr.
101X : Part Number & Rank
V : VDE Option
Y : Fiscal Year
A : Manufacturing Code
WW : Work Week

ORDERING INFORMATION

TD101X(Z)-GV

TD : , ompany Abbr#
101X : * an" 60J1J?J=J!J(J5J3J7J<8
K : Tape and * eel Option 6T1JT?8
G : Green
) :)D1 Option 6) or 4one8

LABEL INFORMATION



福建天电光电有限公司
FUJIAN LIGHTNING OPTOELECTRONIC CO., LTD.



Part No : XXXXXXXXXXXXX Bin Code : X



Lot No : XXXXXXXXXXXX

Date Code : XXXX

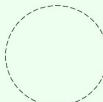
Q'ty : XXXX pcs

PACKING QUANTITY

Option	Quantity	Quantity – Inner box	Quantity – Outer box
T1	=000 2nitsJ * eel	= * eelsJanner bo-	(Anner bo-JOuter bo- D ! (" 2nits
T?	=000 2nitsJ * eel	= * eelsJanner bo-	(Anner bo-JOuter bo- D ! (" 2nits



REFLOW INFORMATION

REFLOW PROFILE

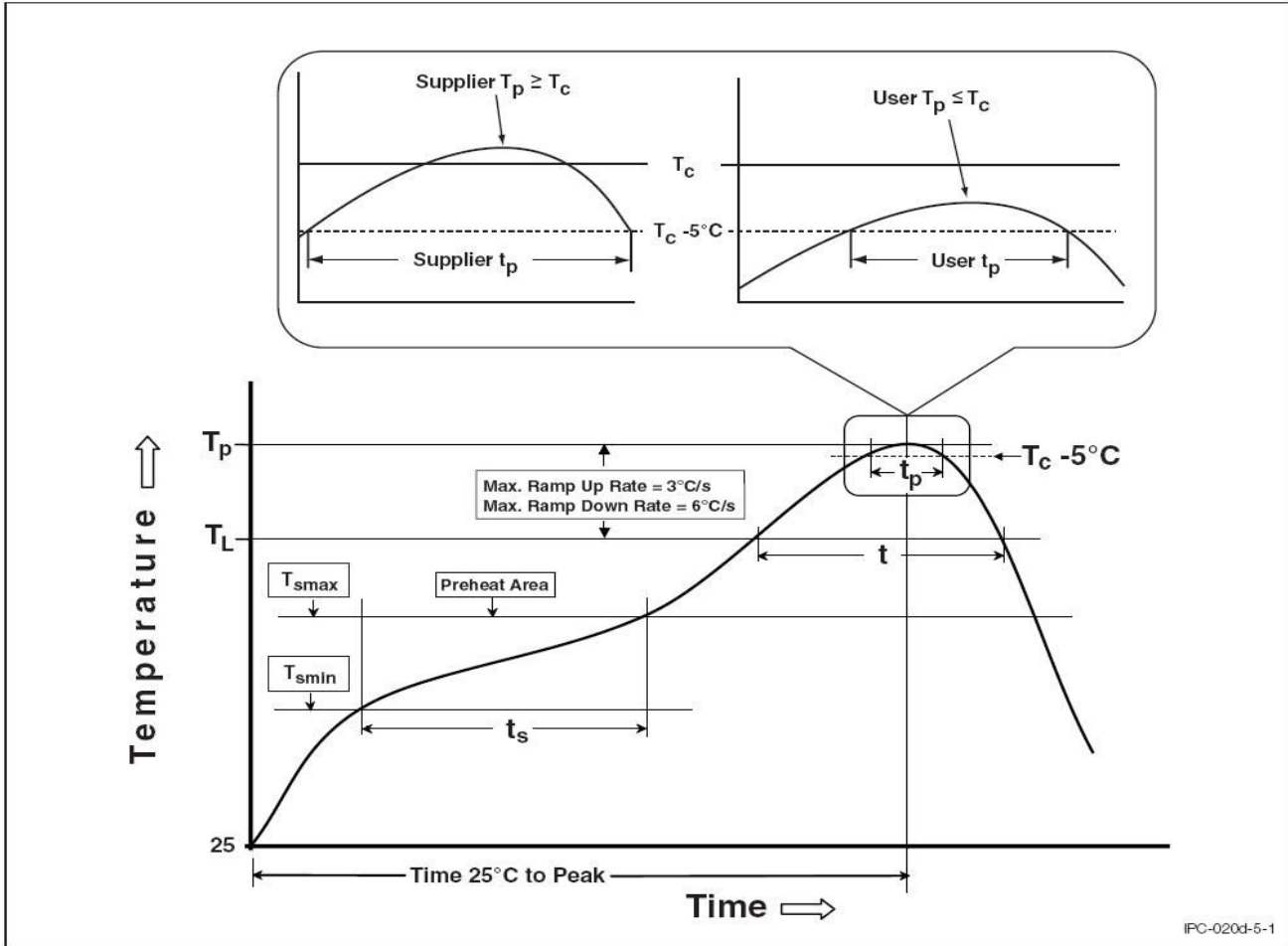

IPC-020d-5-1

Profile Feature	Sn-Pb Assembly Profile	Pb-Free Assembly Profile
Temperature +in# 6Tsmmin8	100	1(0/ ,
Temperature +a-# 6Tsmma-8	1(0	?00/ ,
Time 6ts8 from 6Tsmmin to Tsmma-8	50.1?0 seconds	50.1?0 seconds
* amp.up * ate 6tL to t 8	=/ , Jsecond ma-#	=/ , Jsecond ma-#
Li>uidous Temperature 6TL8	17=/ ,	?13/ ,
Time 6tL8 + aintained Abo&e 6TL8	50 : 1(0 seconds	50 : 1(0 seconds
ea" ;ody ac"age Temperature	?=(/ , L0/ , J.(/ ,	?50/ , L0/ , J.(/ ,
Time 6t 8 within (/ , of ?50/ ,	?0 seconds	=0 seconds
* amp.down * ate 6T to TL8	5/ , Jsecond ma-	5/ , Jsecond ma-
Time ?(/ , to ea" Temperature	5 minutes ma-#	7 minutes ma-#



TD101X Series

LSOP4, DC Input, Photo Transistor Coupler

DISCLAIMER

LAG ' T4A4G is continually improving the quality, reliability, function and design. LAG ' T4A4G reserves the right to make changes without further notices.

The characteristic curves shown in this datasheet are representing typical performance which are not guaranteed.

LAG ' T4A4G makes no warranty, representation or guarantee regarding the suitability of the products for any particular purpose or the continuing production of any product. To the maximum extent permitted by applicable law, LAG ' T4A4G disclaims both any and all liability arising out of the application or use of any product, both any and all liability, including without limitation special, consequential or incidental damages, and both any and all implied warranties, including warranties of fitness for particular

The products shown in this publication are designed for the general use in electronic applications such as office automation, equipment, communications devices, audio/visual equipment, electrical application and instrumentation purpose, non-infringement and merchantability.

This product is not intended to be used for military, aircraft, automotive, medical, life sustaining or lifesaving applications or any other application which can result in human injury or death.

Please contact LAG ' T4A4G sales agent for special application request.

Immersion unit's body in solder paste is not recommended.

Parameters provided in datasheets may vary in different applications and performance may vary over time. All operating parameters, including typical parameters, must be validated in each customer application by the customer's technical experts. Product specifications do not expand or otherwise modify LAG ' T4A4G's terms and conditions of purchase, including but not limited to the warranty expressed therein.

Discoloration might be occurred on the package surface after soldering, reflow or long time use. It neither impacts the performance nor reliability.